



STEPPING MOTORS catalogue

SANYO DENKI **SANMOTION**
STEPPING SYSTEMS



Motion Control Systems

STEPPING MOTORS catalogue

Catalogo *MOTORI PASSO-PASSO*

SANYO DENKI

SANMOTION
STEPPING SYSTEMS



Warning / Attenzione

- The sole purpose of this catalogue is as a general introduction to our products, in order to allow an orientation as well as a choice among them. Detailed information concerning limitations and installation/utilization procedures are described in the manuals relating to each product. It is therefore essential to strictly refer to these enclosed technical manuals for a correct use, in accordance with current standards.

- All those products for which a specific obligation is required, as per law regulation in force in the European Community countries, bear the EC marking stating they are in accordance with the related directives (depending on the products, 2006/95/CE and/or 2004/108/CE and subsequent modifications and integration).

- All products are classed as components foreseen to be integrated in a more complex machine or installation by a professional assembler, expert in the field of motor drives and in their related problems. Only a professional assembler can install and put in service this component. The necessary installation recommendations are included in the technical manuals.

- R.T.A. reserves the right to modify the products at any time and without prior notice (including, but not limited to, characteristics, availability and prices).

- *Unico scopo di questo catalogo è una presentazione generale dei prodotti atta a consentire un orientamento e una scelta tra gli stessi. Informazioni precise e dettagliate in merito alle limitazioni e modalità di installazione ed uso sono riportate nei manuali tecnici relativi ai singoli prodotti. Pertanto, per un loro uso corretto e conforme alle normative in vigore, è indispensabile fare riferimento a tali manuali tecnici.*

- *Tutti quei prodotti per i quali vi è obbligo specifico, ai sensi delle disposizioni di legge vigenti nei paesi della Comunità Europea, recano la marcatura CE attestante la conformità alle direttive che li riguardano (a seconda del prodotto, direttiva 2006/95/CE e/o 2004/108/CE e successive modifiche ed integrazioni).*

- *Tutti i prodotti riportati nel catalogo sono componenti atti ad essere integrati in apparecchiature o macchine più complesse. La loro installazione e messa in servizio deve essere fatta da un assemblatore professionale competente nel settore degli azionamenti per motori e delle loro problematiche. Le necessarie prescrizioni e indicazioni per la installazione sono incluse nei manuali tecnici.*

- *R.T.A. si riserva il diritto di apportare modifiche ai prodotti (includendo, senza limitazione alcuna, caratteristiche, disponibilità e prezzi) in qualsiasi momento e senza preavviso.*

- SANYO DENKI, fondata nel 1927 in Giappone, ha iniziato lo sviluppo e la produzione di servomotori nel 1952, di stepping motors nel 1959 e dei ventilatori negli anni '60, mentre è attiva nel settore dei gruppi di continuità dalla fine degli anni '50.
- La società, quotata alla borsa di Tokyo dal 1962, è dotata di una struttura produttiva, logistica e commerciale multinazionale, con filiali dirette in tutti i più importanti paesi industrializzati. Essa impiega oltre 2.600 addetti in tutto il mondo.
- L'esperienza e le competenze accumulate in oltre 80 anni di attività ne fanno oggi un leader mondiale del settore, sia per potenzialità di sviluppo di nuovi prodotti ad alte prestazioni, sia per la capacità di trasferire nelle produzioni di serie le innovazioni tecnologiche introdotte, mantenendo la tradizionale altissima affidabilità.
- La produzione in grande serie (svariati milioni di unità annue) viene effettuata facendo uso di linee ad elevatissimo livello di robotizzazione. In tal modo viene assicurato un ottimo rapporto prezzo/prestazioni, collegato ad una costanza della qualità e ad una grande ripetibilità delle caratteristiche dei singoli esemplari.
- Con la recente apertura (2009) della fabbrica di Kangawa, in Giappone, SANYO DENKI si è dotata di uno degli stabilimenti più automatizzati, produttivi ed eco-compatibili al mondo nel settore dell'automazione industriale.
- The Company is listed on the Tokyo Stock Exchange since 1962. It features multinational operations and sales, with direct subsidiaries in all major industrialized countries. The Company employs over 2,600 people worldwide.
- The experience and skills collected in over 80 years of activity has made SANYO DENKI an international leader in this sector, both for the development of new highperformance products and the mass-production quality and technological consistency. SANYO DENKI is also proud of a strong track record of product reliability that is worldwide recognized.
- Mass-production (several million of units per year) is carried out making use of fully automated lines, equipped with high level robotics. In this way, an excellent price / performance ratio is insured, in connection with high product quality and strong repeatability.
- With the recent opening of the Kangawa Factory in Japan (2009), SANYO DENKI has developed one of the most automated, efficient and eco-friendly manufacturing plant in the world of industrial automation.

SANYO DENKI & R.T.A.



Motion Control Systems

- R.T.A. è distributore per l'Italia di SANYO DENKI dal 1989. R.T.A. ha successivamente acquisito la distribuzione per la Germania e la Spagna, rispettivamente nel 2001 e nel 2008.
- In oltre 20 anni di collaborazione SANYO DENKI ed R.T.A. hanno sviluppato con successo una partnership strategica forte e stabile. Essa è basata su una elevatissima complementarità fra prodotti (azionamenti R.T.A. e motori passo-passo SANYO DENKI), fra tecnologie (sistemi passo-passo e brushless) e fra linee di business (motori elettrici e ventilatori).
- Negli anni, la partnership fra R.T.A. e SANYO DENKI ha consentito di realizzare una forte penetrazione di mercato in Italia e l'introduzione di prodotti ad alta tecnologia ed innovatività. In anni più recenti, tale rapporto di collaborazione è evoluto e si è arricchito grazie all'ingresso in nuovi mercati europei altamente strategici, quali la Germania e la Spagna.
- During over 20 years of collaboration, RTA and SANYO DENKI have successfully developed a strong and stable strategic partnership. It is based on a strong coupling between products (RTA drives and SANYO DENKI stepper motors), technologies (stepper and brushless systems) and business lines (motors and fans).
- Over the years, the partnership among R.T.A. and SANYO DENKI has achieved a strong market penetration in Italy, through the introduction of high technology products and innovative solutions. In more recent years, this partnership has evolved and enriched, entering into new highly strategic European markets such as Germany and Spain.

• SANYO DENKI experience and skills collected in over 80 years of activity in the motion control sector are able to offer a wide range of motors characterized by high performances:

- high quality and reliability
- low acoustic noise
- excellent thermal performance

• The broad range of motors proposed by R.T.A., selected from the more than 800 models in the SANYO DENKI's catalogue and supported by a very large stock of motors, always available in the warehouse, allows to face and solve in the best way a great variety of automation problems.

R.T.A. OFFERS TWO PRODUCT LINES:

- **H & STANDARD SERIES:** motors with flange size from 1.7" (NEMA 17, □ 42mm) up to 4.2" (NEMA 42, □ 106.4mm) with holding torque from 12.5 Ncm to 24.6 Nm.
- **SM SERIES:** motors with flange size 3.4" (NEMA 34, □ 85.5mm) at high torque (from 3.6 Nm to 9.2 Nm).

• L'esperienza e le competenze di SANYO DENKI accumulate in oltre 80 anni di attività nel settore del motion control hanno permesso di realizzare una vasta gamma di motori caratterizzati da alte prestazioni:

- alta qualità ed affidabilità
- bassa rumorosità acustica,
- ottima performance da un punto di vista termico

• L'ampia selezione di motori passo-passo proposta da R.T.A., scelta tra gli oltre 800 modelli SANYO DENKI e supportata da un consistente stock di motori sempre a magazzino, permette di affrontare e risolvere nel modo più efficiente una grande varietà di problemi di automazione.

R.T.A. PROPONE DUE LINEE DI PRODOTTI:

- **SERIE H & STANDARD:** motori con flangia da 1,7" (NEMA 17, □ 42mm) fino a 4,2" (NEMA 42, □ 106,4mm) con coppie di tenuta da 12,5 Ncm a 24,6 Nm.
- **SERIE SM:** motori con flangia 3,4" (NEMA 34 □ 85,5mm) ad alta intensità di coppia (da 3,6 Nm a 9,2 Nm).

Flange size Dim. Flangia	□ Nema 17 42 mm	□ 50 mm	□ Nema 23 56 mm	□ 60 mm	□ Nema 34 86 mm	□ Nema 42 106.4 mm
H Series	✓	✓	✓	✓	✓	✓
SM Series					✓	



- High performance in terms of torque and power.
 - High torque/inertia ratios.
 - Low acoustic noise.
 - Limited vibrations generated by the motor body.
 - Extremely performing thermal behaviour.
 - Optimized construction for a better exploitation of the advantages in terms of precision and noiselessness offered by microstepping drives.
 - H and STANDARD stepping motors include: version with terminal box and IP55 protection degree.
- *Elevate prestazioni in termini di coppia e di potenza.*
 - *Elevati rapporti coppia/inerzia.*
 - *Bassa rumorosità acustica.*
 - *Limitate vibrazioni generate dal corpo motore.*
 - *Ottime performance da un punto di vista termico.*
 - *Costruzione ottimizzata per meglio sfruttare i vantaggi in termini di precisione e silenziosità offerti da azionamenti ad alto frazionamento di passo.*
 - *Tra i nostri prodotti disponibili: versioni con terminal box, grado di protezione IP55.*



SM series stepping motors

- The best performance in terms of torque and power.
 - Optimized for use with drives with any type of power supply, also directly from main (230 VAC).
 - Insulation voltage 250 VAC.
 - Class F insulation.
 - Optimized thermal and acoustic efficiency allows the use in high power and high environment temperature applications.
 - Shaft with diameter 14 mm: robust and able to bear high radial loads.
 - CE, UL and CSA marking allowing the use in applications and machinery for use in Italy and worldwide.
- *Prestazioni ancora più elevate in termini di coppia e di potenza.*
 - *Costruzione ottimizzata per l'utilizzo con qualsiasi tipo di alimentazione, anche diretta da rete (230 VAC).*
 - *Tensione di isolamento 250 VAC.*
 - *Classe di isolamento F.*
 - *Rendimento termico ed acustico ulteriormente ottimizzato rispetto alla serie H, per permetterne l'utilizzo in applicazioni ad alta potenza e ad alta temperatura ambiente.*
 - *Albero di diametro 14 mm in grado di sostenere elevati carichi radiali.*
 - *Marchatura CE, UL e CSA per impieghi in applicazioni e macchinari destinati sia al mercato italiano che a quello mondiale.*



H & STANDARD Series SANYO DENKI Stepping Motors	HOLDING TORQUE COPPIA DI TENUTA (Ncm.)	FLANGE SIZE DIMENSIONE FLANGIA (mm.)	LENGTH LUNGHEZZA (mm.)	CURRENT CORRENTE (Amp)	TECHNICAL DATA DATI TECNICI (page/pagina)
SIZE 1.7" - □ 42 mm					
103-546-55500	12.5	□ 42	32.5	0.20	6
103-546-5342	19	□ 42	32.5	0.42*	7
103-547-52500 (103-547-52300)	25	□ 42	36.5	0.70*	8
103-H548-04500	37	□ 42	41	0.90*	9
103-H5210-4240	51	□ 42	48	1.00	10
SIZE 50 mm - □ 50 mm					
103-H6701-0140 (103-H6701-0113)	38	□ 50	39.8	0.70*	11
103-H6703-0440	68	□ 50	51.3	1.40*	12
SIZE 2.2" - □ 56 mm					
103-H7123-0140	110	□ 56	53.8	0.70*	13
103-H7123-0440	110	□ 56	53.8	1.50*	14
103-H7123-5040 (103-H7123-5010)	85	□ 56	53.8	2.00	15
103-H7123-0740 (103-H7123-0710)	110	□ 56	53.8	2.20*	16
103-H7123-1749 (103-H7123-1710)	110	□ 56	53.8	4.00	17
103-H7126-0140	165	□ 56	75.8	0.75*	18
103-H7126-0740 (103-H7126-0710)	165	□ 56	75.8	2.20*	19
103-H7126-1740 (103-H7126-1710)	165	□ 56	75.8	4.00	20
103-H7126-6640 (103-H7126-6610)	165	□ 56	75.8	5.60	21
SIZE 60 mm - □ 60 mm					
103-H7823-1740 (103-H7823-1714)	300	□ 60	85.8	4.00	22
SIZE 3.4" - Ø 85.8 mm					
103-845-6741 (103-845-6711)	510	Ø 85.8	130.0	9.50	23
103-845-67S1	510	Ø 85.8	133.0	9.50	24
103-845-67S41	510	Ø 85.8	153.0	9.50	25
103-H8221-6241 (103-H8221-6211)	300	Ø 85.8	62.0	6.00	26
103-H8221-62S41	300	Ø 85.8	82.9	6.00	27
103-H8222-6340 (103-H8222-6310)	560	Ø 85.8	92.2	6.00	28
103-H8223-6540 (103-H8223-6510)	790	Ø 85.8	125.9	9.00	29
SIZE 4.2" - □ 106.4 mm					
103-8932-6451 (103-8932-6421)	1330	□ 106.4	186.9	12.70	30
103-8960-6551	2060	□ 106.4	245	14.10	31
103-H89222-6341	1620	□ 106.4	163.0	6.00	32
103-H89222-6541	1620	□ 106.4	163.0	10.00	33
103-H89223-6341 (103-H89223-6311)	2460	□ 106.4	221.0	6.00	34
103-H89223-6641 (103-H89223-6611)	2460	□ 106.4	221.0	12.00	35

SM Series SANYO DENKI Stepping Motors	HOLDING TORQUE COPPIA DI TENUTA (Ncm.)	FLANGE SIZE DIMENSIONE FLANGIA (mm.)	LENGTH LUNGHEZZA (mm.)	CURRENT CORRENTE (Amp)	TECHNICAL DATA DATI TECNICI (page/pagina)
SIZE 3.4" - □ 85.5 mm					
SM 2861-5055	360	□ 85.5	66.0	2	36
SM 2861-5255 (SM 2861-5225)	360	□ 85.5	66.0	6	37
SM 2862-5055	700	□ 85.5	96.5	2	38
SM 2862-5155 (SM 2862-5125)	700	□ 85.5	96.5	4	39
SM 2862-5156	700	□ 85.5	128.4	4	40
SM 2862-5255 (SM 2862-5225)	700	□ 85.5	96.5	6	41
SM 2863-5155 (SM 2863-5126)	920	□ 85.5	127	4	42
SM 2863-5255 (SM 2863-5225)	920	□ 85.5	127	6	43

NOTE: Codes between brackets refer to double shaft models.
 NOTA: I codici tra parentesi si riferiscono ai modelli bialbero.

*Bipolar series connection.
 * Collegamento bipolare serie.

- The following tables show suggested motor/drive coupling between SANYO DENKI stepping motors and R.T.A. drives.
- R.T.A. suggests contacting its commercial personnel to verify and validate the optimal motor/drive coupling.
- PLUS E and PLUS L series drives require coupling with R.T.A. EM series motors. Ask R.T.A. for details.
- Nelle tabelle seguenti sono indicati gli accoppiamenti motore/serie di azionamenti consigliati da R.T.A.
- R.T.A. consiglia di contattare il proprio personale commerciale per verificare e validare l'ottimale accoppiamento fra motore e azionamento.
- Gli azionamenti serie PLUS E e PLUS L prevedono l'accoppiamento con motori serie EM. Contattare R.T.A. per ulteriori dettagli.

H & STANDARD Series SANYO DENKI Stepping Motors Motori passo-passo SANYO DENKI serie H e Standard		R.T.A. Drives / Azionamenti R.T.A.*							
		CSD	NDC	HGD	PLUS A/B	PLUS K	X-PLUS B	X-MIND B	X-MIND K
103-H548-04500	Size 1.7" - □ 42 mm	●	●	●					
103-H5210-4240	Size 1.7" - □ 42 mm	●	●	●					
103-H6701-0140 (103-H6701-0113)	Size 50 mm - □ 50 mm	●	●	●					
103-H6703-0440	Size 50 mm - □ 50 mm	●	●	●					
103-H7123-0140	Size 2.2" - □ 56 mm	●	●	●					
103-H7123-0440	Size 2.2" - □ 56 mm	●	●	●					
103-H7123-0740 (103-H7123-0710)	Size 2.2" - □ 56 mm	●	●	●					
103-H7123-1749 (103-H7123-1710)	Size 2.2" - □ 56 mm	●	●	●	●	●			
103-H7123-5040 (103-H7123-5010)	Size 2.2" - □ 56 mm	●	●	●					
103-H7126-0140	Size 2.2" - □ 56 mm	●	●	●					
103-H7126-0740 (103-H7126-0710)	Size 2.2" - □ 56 mm	●	●	●					
103-H7126-1740 (103-H7126-1710)	Size 2.2" - □ 56 mm	●	●	●	●	●			
103-H7126-6640 (103-H7126-6610)	Size 2.2" - □ 56 mm		●	●	●	●			
103-H7823-1740 (103-H7823-1714)	Size 60 mm - □ 60 mm	●	●	●	●	●			
103-845-6741 (103-845-6711)	Size 3.4" - ∅ 85.8 mm				●	●			
103-845-67S1	Size 3.4" - ∅ 85.8 mm				●	●			
103-845-67S41	Size 3.4" - ∅ 85.8 mm				●	●			
103-H8221-6241 (103-H8221-6211)	Size 3.4" - ∅ 85.8 mm		●	●	●	●			
103-H8222-6340 (103-H8222-6310)	Size 3.4" - ∅ 85.8 mm		●	●	●	●			
103-H8223-6540 (103-H8223-6510)	Size 3.4" - ∅ 85.8 mm				●	●			
103-H8221-62S41	Size 3.4" - ∅ 85.8 mm		●	●	●	●			
103-H89222-6341	Size 4.2" - □ 106.4 mm				●	●		●	●
103-H89223-6341 (103-H89223-6311)	Size 4.2" - □ 106.4 mm				●	●		●	●

SM Series SANYO DENKI Stepping Motors Motori passo-passo SANYO DENKI serie SM		R.T.A. Drives / Azionamenti R.T.A.*							
		CSD	NDC	HGD	PLUS A/B	PLUS K	X-PLUS B	X-MIND B	X-MIND K
SM2861-5055	Size 3.4" - □ 85.5 mm						●	●	●
SM2861-5255 (SM2861-5225)	Size 3.4" - □ 85.5 mm		●	●	●	●			
SM2862-5055	Size 3.4" - □ 85.5 mm						●	●	●
SM2862-5155 (SM2862-5125)	Size 3.4" - □ 85.5 mm						●	●	●
SM2862-5255 (SM2862-5225)	Size 3.4" - □ 85.5 mm		●	●	●	●			
SM2862-5156	Size 3.4" - □ 85.5 mm						●	●	●
SM2863-5155 (SM2863-5126)	Size 3.4" - □ 85.5 mm						●	●	●
SM2863-5255 (SM2863-5225)	Size 3.4" - □ 85.5 mm		●	●	●	●			

NOTE: Codes between brackets refer to double shaft models.
 NOTA: I codici tra parentesi si riferiscono ai modelli bialbero.

*For more info, please refer to www.rta.it
 * Per ulteriori informazioni, si veda www.rta.it

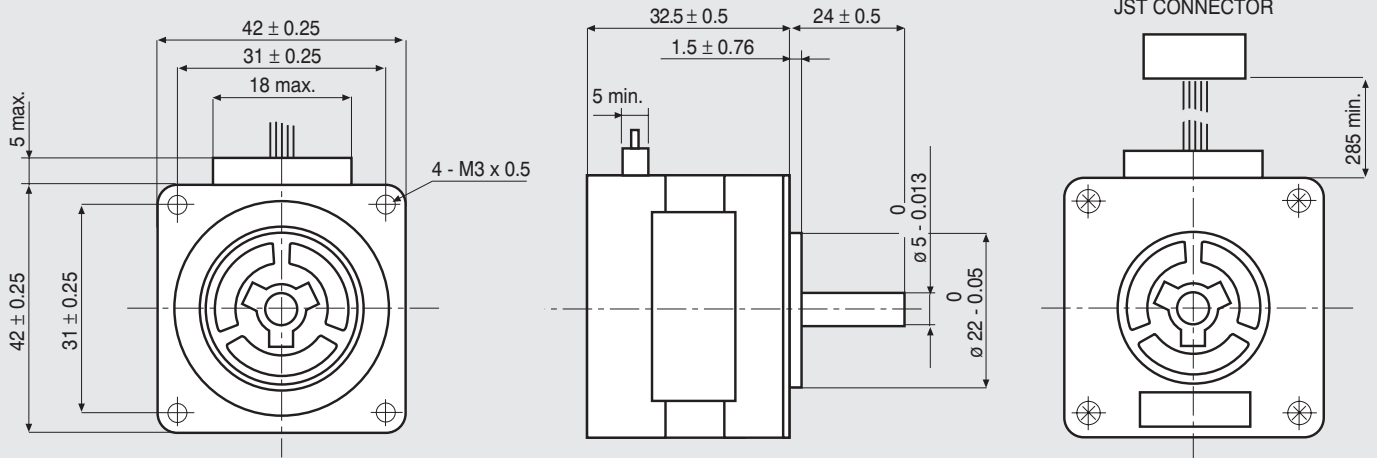

MOTOR CONNECTOR IS JST mod. EHR-4/
EHR-6 A 4 / 6 POLES FEMALE.
FOR CONNECTION USE JST mod. B4B-EH-A/
B6B-EH-A MALE CONNECTOR.

Dimensions in mm.

FEATURES CARATTERISTICHE		MODEL MODELLO	103 - 546 - 55500
BASIC STEP ANGLE			1.8° ± 0.09°
BIPOLAR CURRENT	(Amp)		0.2
UNIPOLAR CURRENT	(Amp)		
RESISTANCE	(Ohm)		37.5
INDUCTANCE	(mH)		52
BIPOLAR HOLDING TORQUE	(Ncm)		12.5
UNIPOLAR HOLDING TORQUE	(Ncm)		
ROTOR INERTIA	(Kg ^m 2 x 10 ⁻⁷)		20
THEORETICAL ACCELERATION	(rad x sec. ⁻²)		63000
BACK E.M.F.	(V/Krpm)		47
MASS	(Kg)		0.2
LEADS CODE			V

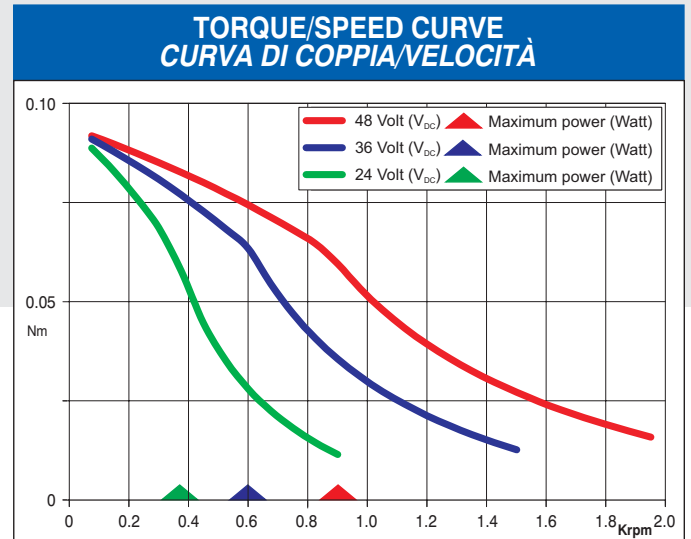

Suggested driver: contact R.T.A.

R.T.A. s.r.l. PAVIA (ITALY) SANYO DENKI CO., Ltd (JAPAN)

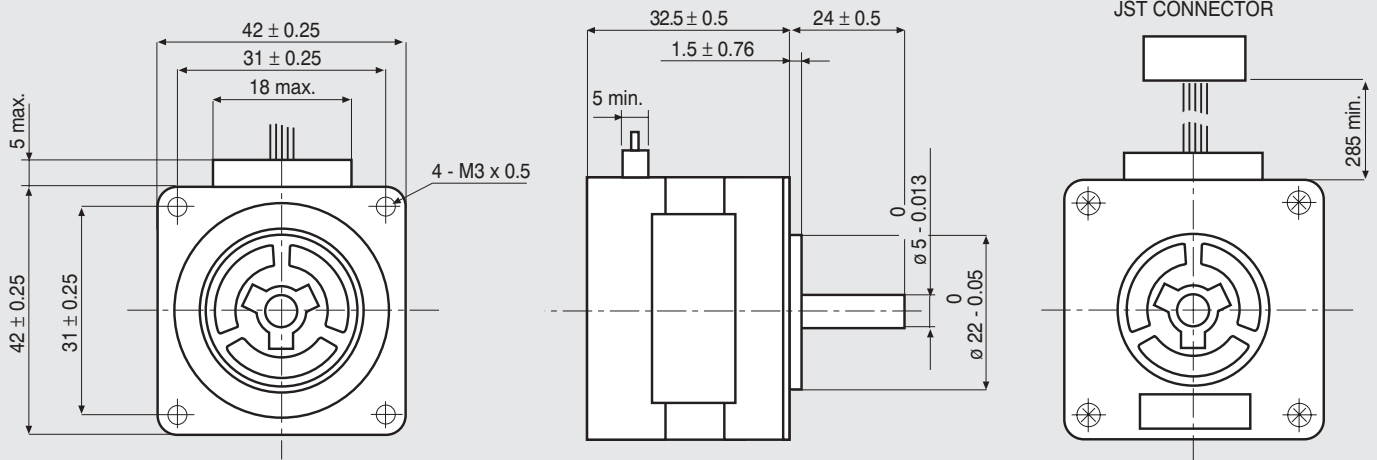

MOTOR CONNECTOR IS JST mod. EHR-4/
EHR-6 A 4 / 6 POLES FEMALE.
FOR CONNECTION USE JST mod. B4B-EH-A/
B6B-EH-A MALE CONNECTOR.

Dimensions in mm.

FEATURES CARATTERISTICHE		MODEL MODELLO	103 - 546 - 5342
BASIC STEP ANGLE			1.8° ± 0.09°
BIPOLAR CURRENT	(Amp)		0.42 ^(*)
UNIPOLAR CURRENT	(Amp)		0.6
RESISTANCE	(Ohm)		6.7
INDUCTANCE	(mH)		5.4
BIPOLAR HOLDING TORQUE	(Ncm)		19
UNIPOLAR HOLDING TORQUE	(Ncm)		14.5
ROTOR INERTIA	(Kg ^m 2 x 10 ⁻⁷)		30
THEORETICAL ACCELERATION	(rad x sec. ⁻²)		63000
BACK E.M.F.	(V/Krpm)		18
MASS	(Kg)		0.2
LEADS CODE			IV

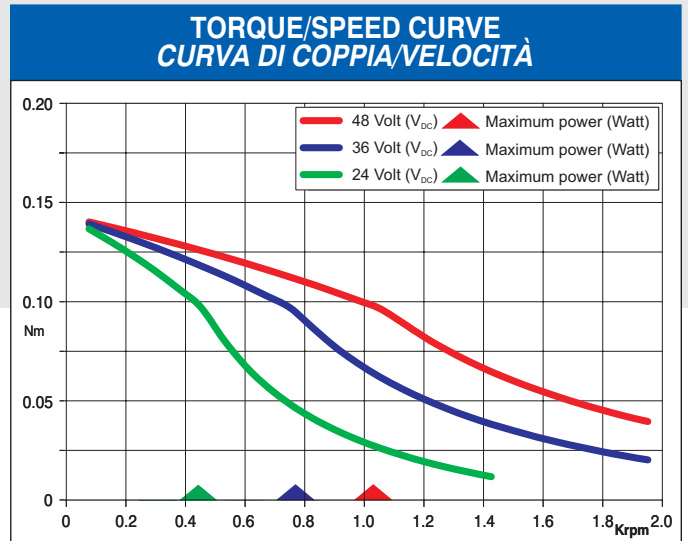

^(*) Bipolar series connection.
^(*) Collegamento bipolare serie.



Suggested driver: contact R.T.A.

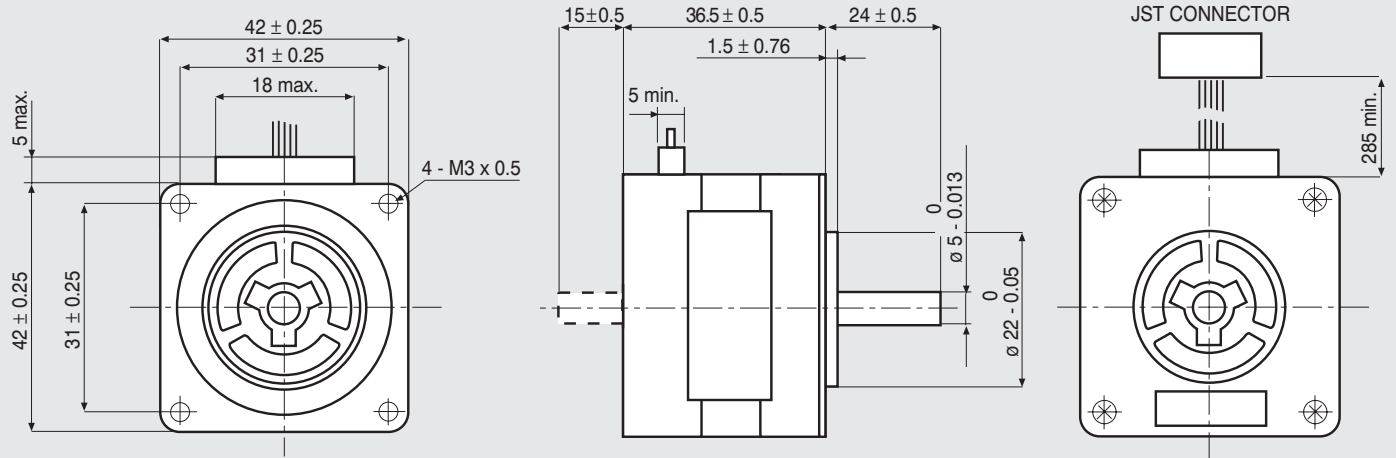

MOTOR CONNECTOR IS JST mod. EHR-4/
EHR-6 A 4 / 6 POLES FEMALE.
FOR CONNECTION USE JST mod. B4B-EH-A/
B6B-EH-A MALE CONNECTOR.

Dimensions in mm.

FEATURES CARATTERISTICHE		MODEL MODELLO	103 - 547 - 52500 (103 - 547 - 52300)
BASIC STEP ANGLE			1.8° ± 0.09°
BIPOLAR CURRENT	(Amp)		0.7 ^(*)
UNIPOLAR CURRENT	(Amp)		1.0
RESISTANCE	(Ohm)		3.15
INDUCTANCE	(mH)		3
BIPOLAR HOLDING TORQUE	(Ncm)		25
UNIPOLAR HOLDING TORQUE	(Ncm)		19
ROTOR INERTIA	(Kg ^m 2 x 10 ⁻⁷)		43
THEORETICAL ACCELERATION	(rad x sec. ⁻²)		59000
BACK E.M.F.	(V/Krpm)		14
MASS	(Kg)		0.24
LEADS CODE			IV

Codes between brackets refer to double shaft models.
Le sigle fra parentesi si riferiscono ai modelli bialbero.

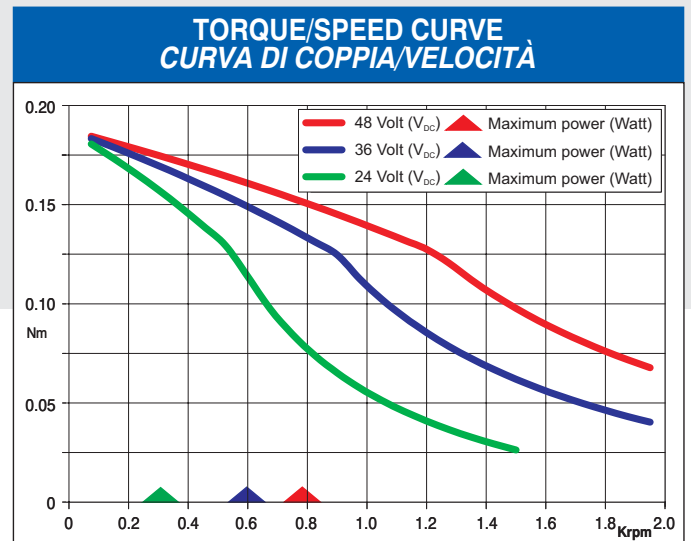

^(*) Bipolar series connection.
^(*) Collegamento bipolare serie.



Suggested driver: contact R.T.A.

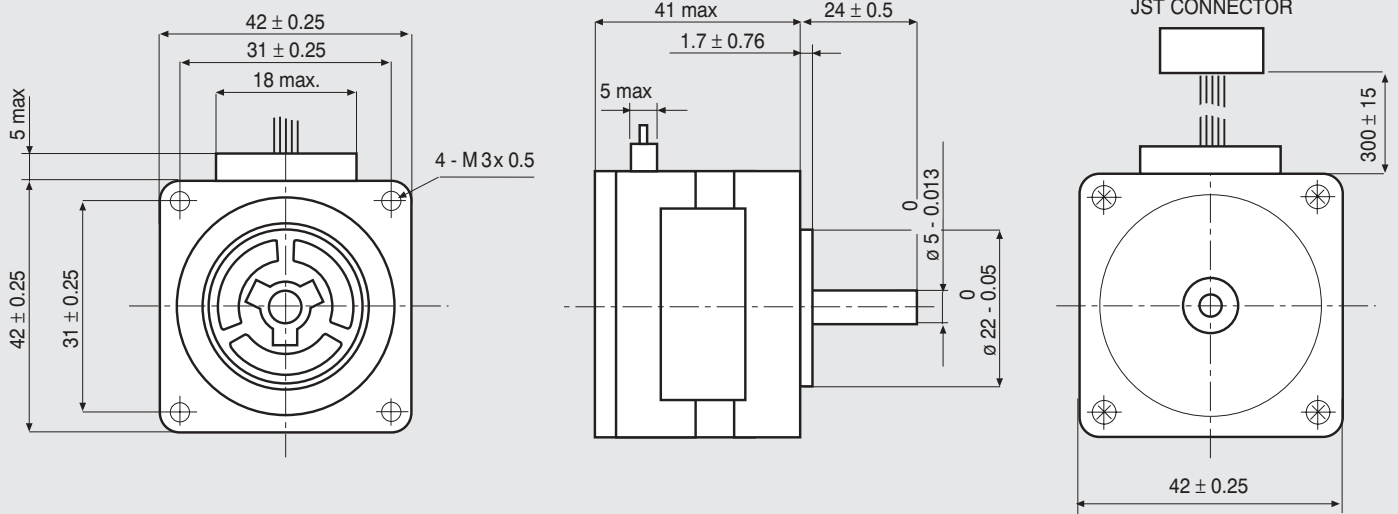

MOTOR CONNECTOR IS JST mod. EHR-6A
6 POLES FEMALE.
FOR CONNECTION USE JST
mod. B6B-EH-A MALE CONNECTOR.

Dimensions in mm.

FEATURES CARATTERISTICHE		MODEL MODELLO	103 - H548 - 04500
BASIC STEP ANGLE			1.8° ± 0.09°
BIPOLAR CURRENT	(Amp)		0.9 ^(*)
UNIPOLAR CURRENT	(Amp)		1.2
RESISTANCE	(Ohm)		3
INDUCTANCE	(mH)		4.3
BIPOLAR HOLDING TORQUE	(Ncm)		37
UNIPOLAR HOLDING TORQUE	(Ncm)		27
ROTOR INERTIA	(Kg ^m 2 x 10 ⁻⁷)		53
THEORETICAL ACCELERATION	(rad x sec. ⁻²)		66000
BACK E.M.F.	(V/Krpm)		17
MASS	(Kg)		0.28
LEADS CODE			IV

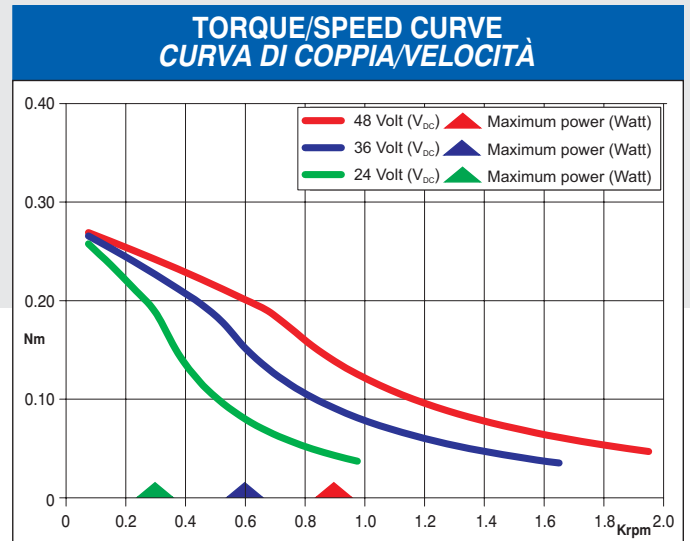

(*) Bipolar series connection.
(*) Collegamento bipolare serie.



Suggested R.T.A. driver: CSD Series, NDC Series, HGD Series.

R.T.A. s.r.l. PAVIA (ITALY) SANYO DENKI CO., Ltd (JAPAN)

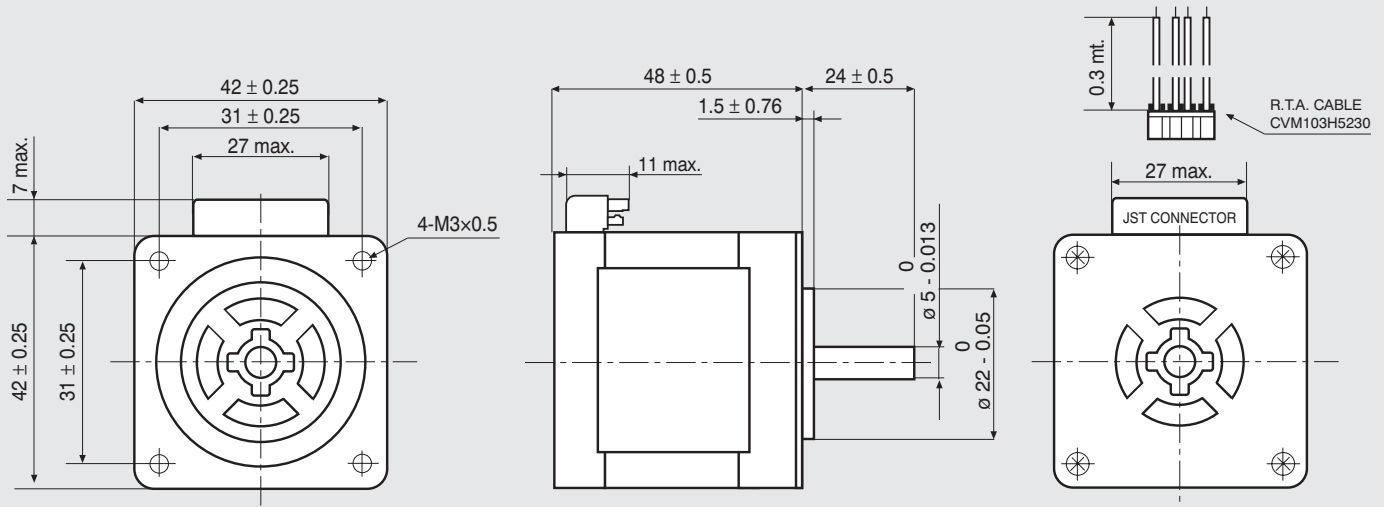

MOTOR CONNECTOR IS JST mod. B6B-EH K 6 POLES MALE.
FOR CONNECTION USE JST mod. EHR-6 FEMALE CONNECTOR AND mod. SEH-001T-P0.6 CONTACTS.
NOTE: 103-H5210-4240 MOTORS NEED CVM103H5230 R.T.A. CABLES. CONTACT R.T.A. FOR FURTHER DETAILS.

Dimensions in mm.

FEATURES CARATTERISTICHE		MODEL MODELLO	103 - H5210 - 4240
BASIC STEP ANGLE			$1.8^\circ \pm 0.09^\circ$
BIPOLAR CURRENT	(Amp)		1.0
UNIPOLAR CURRENT	(Amp)		
RESISTANCE	(Ohm)		4.8
INDUCTANCE	(mH)		9.5
BIPOLAR HOLDING TORQUE	(Ncm)		51
UNIPOLAR HOLDING TORQUE	(Ncm)		
ROTOR INERTIA	(Kgm ² x 10 ⁻⁷)		74
THEORETICAL ACCELERATION	(rad x sec. ⁻²)		69000
BACK E.M.F.	(V/Krpm)		14
MASS	(Kg)		0.35
LEADS CODE			V

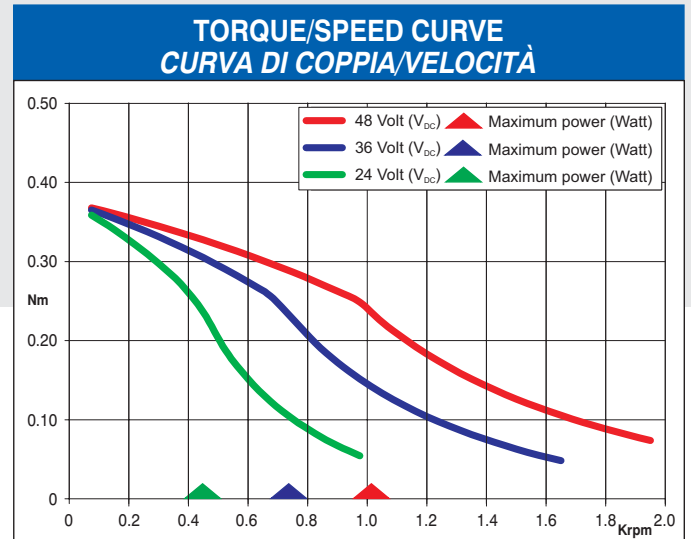

Suggested R.T.A. driver: CSD Series, NDC Series, HGD Series.

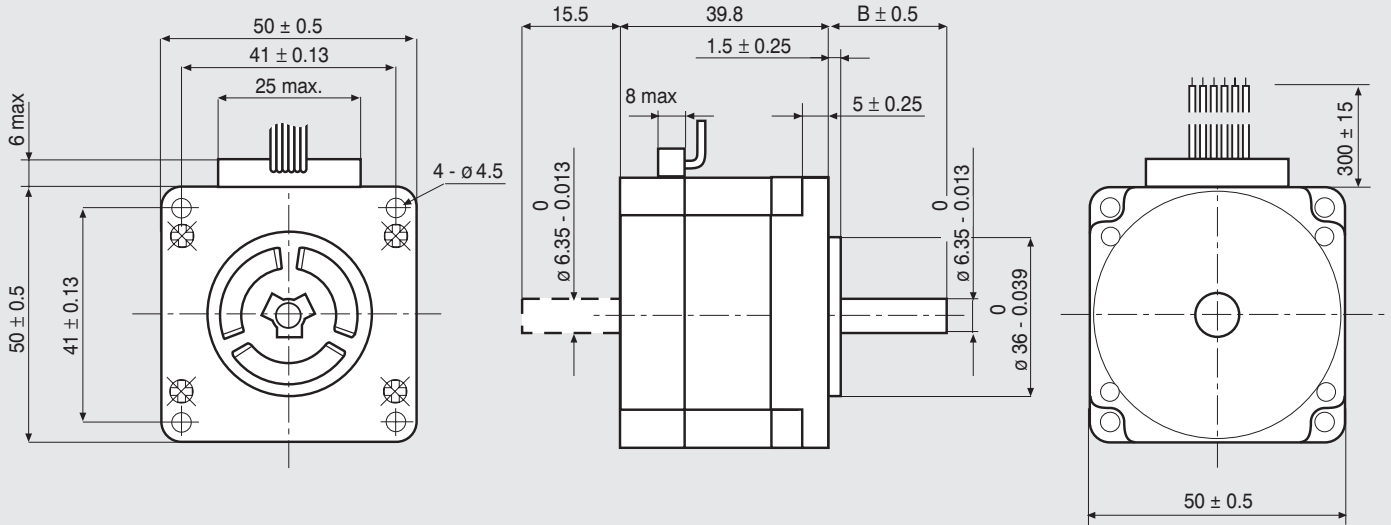

MODEL	B
103 - H6701 - 0140	20.6
103 - H6701 - 0113	28

Dimensions in mm.

FEATURES CARATTERISTICHE		
MODEL MODELLO		103 - H6701 - 0140 (103 - H6701 - 0113)
BASIC STEP ANGLE		1.8° ± 0.09°
BIPOLAR CURRENT	(Amp)	0.7 ^(*)
UNIPOLAR CURRENT	(Amp)	1.0
RESISTANCE	(Ohm)	4.3
INDUCTANCE	(mH)	6.8
BIPOLAR HOLDING TORQUE	(Ncm)	38
UNIPOLAR HOLDING TORQUE	(Ncm)	28
ROTOR INERTIA	(Kgm ² x 10 ⁻⁷)	57
THEORETICAL ACCELERATION	(rad x sec. ⁻²)	66000
BACK E.M.F.	(V/Krpm)	20
MASS	(Kg)	0.35
LEADS CODE		IV

Codes between brackets refer to double shaft models.
Le sigle fra parentesi si riferiscono ai modelli bialbero.

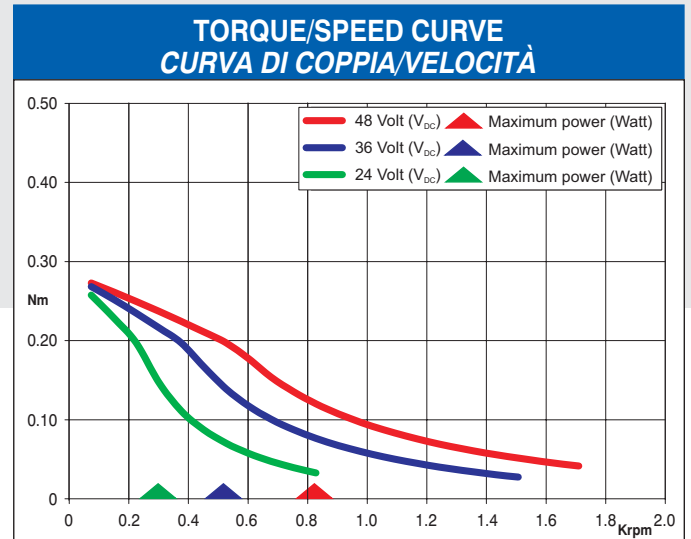

^(*) Bipolar series connection.
^(*) Collegamento bipolare serie.



Suggested R.T.A. driver: CSD Series, NDC Series, HGD Series.

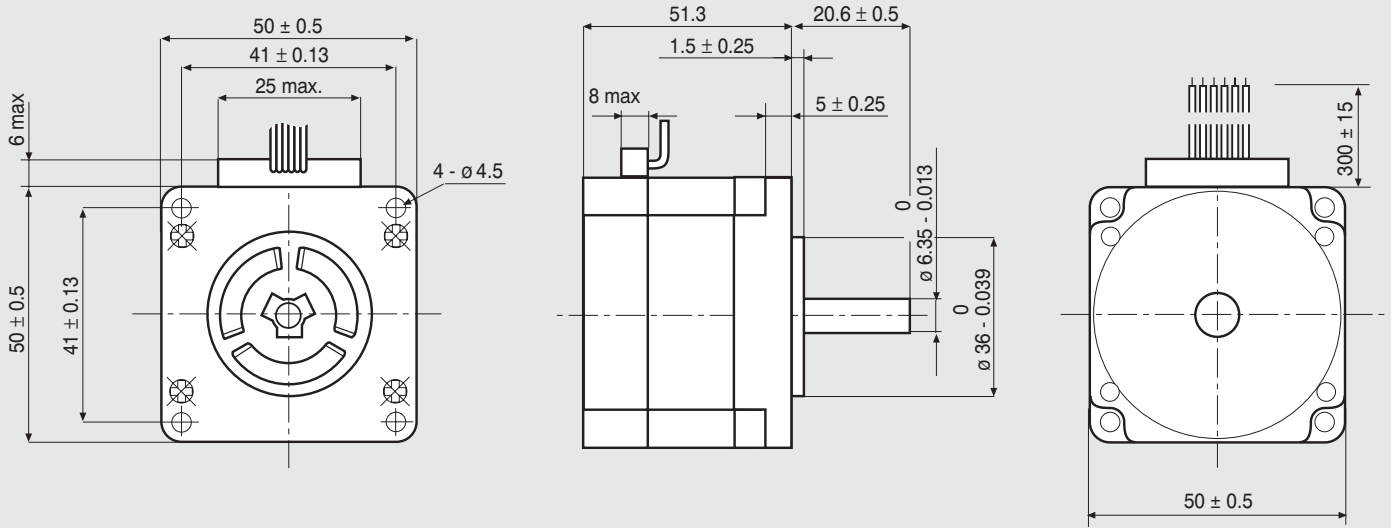

Dimensions in mm.

FEATURES CARATTERISTICHE		
MODEL MODELLO		103 - H6703 - 0440
BASIC STEP ANGLE		1.8° ± 0.09°
BIPOLAR CURRENT	(Amp)	1.4 (*)
UNIPOLAR CURRENT	(Amp)	2.0
RESISTANCE	(Ohm)	1.6
INDUCTANCE	(mH)	3.2
BIPOLAR HOLDING TORQUE	(Ncm)	68
UNIPOLAR HOLDING TORQUE	(Ncm)	49
ROTOR INERTIA	(Kgm ² x 10 ⁻⁷)	118
THEORETICAL ACCELERATION	(rad x sec. ⁻²)	58000
BACK E.M.F.	(V/Krpm)	17.5
MASS	(Kg)	0.5
LEADS CODE		IV

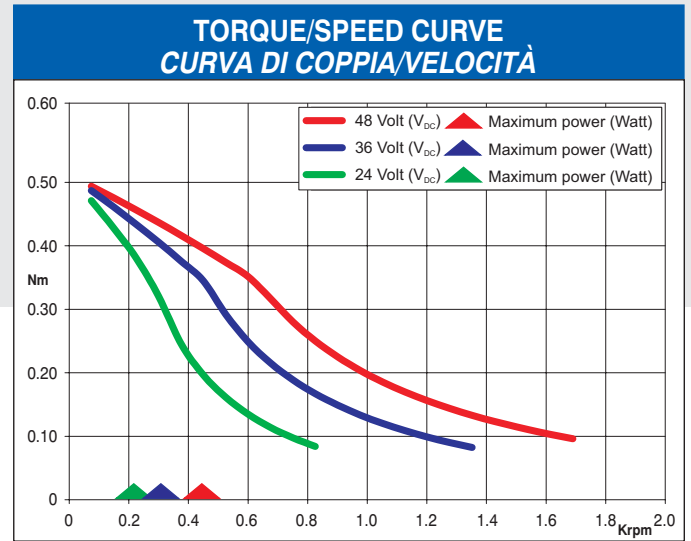

(*) Bipolar series connection.
(*) Collegamento bipolare serie.



Suggested R.T.A. driver: CSD Series, NDC Series, HGD Series.

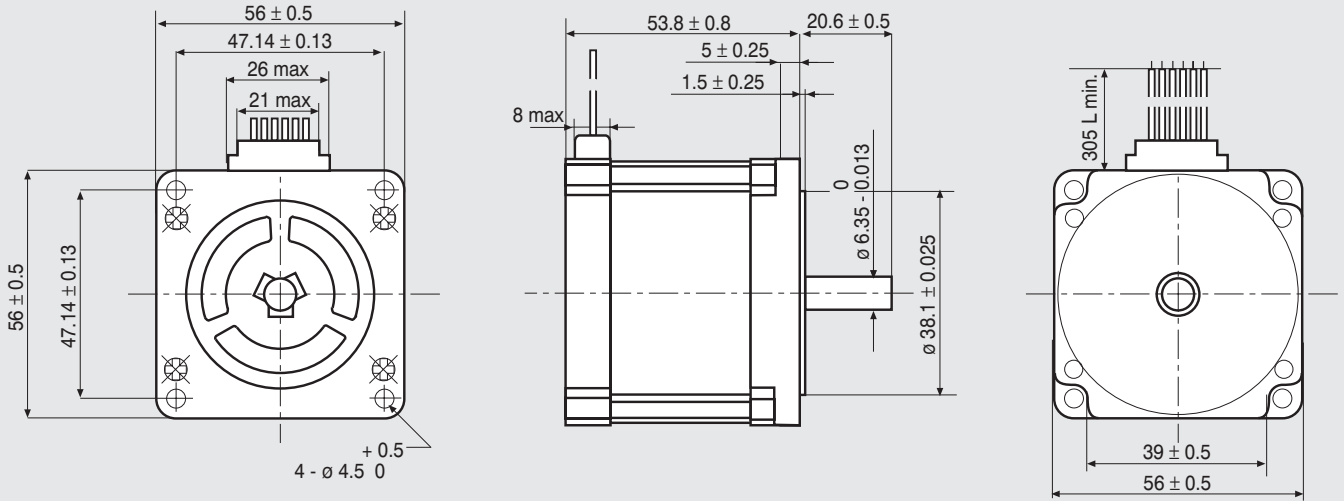

Dimensions in mm.

FEATURES CARATTERISTICHE		
MODEL MODELLO		103 - H7123 - 0140
BASIC STEP ANGLE		$1.8^\circ \pm 0.09^\circ$
BIPOLAR CURRENT	(Amp)	0.7 ^(*)
UNIPOLAR CURRENT	(Amp)	1.0
RESISTANCE	(Ohm)	6.7
INDUCTANCE	(mH)	15
BIPOLAR HOLDING TORQUE	(Ncm)	110
UNIPOLAR HOLDING TORQUE	(Ncm)	85
ROTOR INERTIA	(Kg \cdot m 2 x 10 $^{-7}$)	210
THEORETICAL ACCELERATION	(rad x sec. $^{-2}$)	50000
BACK E.M.F.	(V/Krpm)	60
MASS	(Kg)	0.65
LEADS CODE		IV

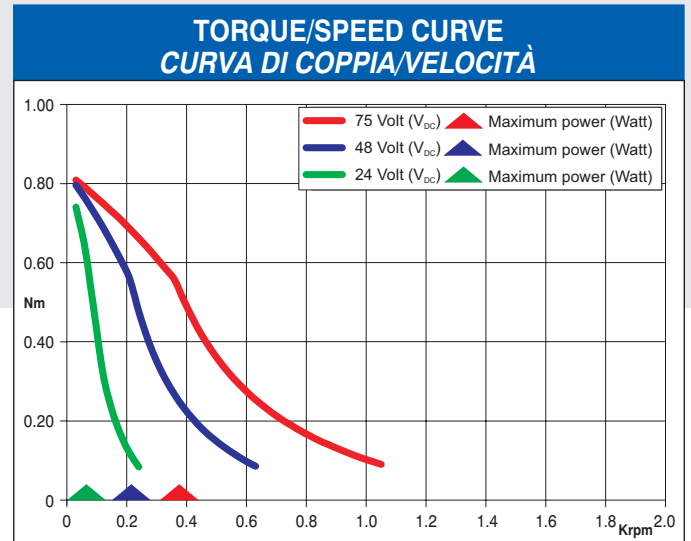

^(*) Bipolar series connection.
^(*) Collegamento bipolare serie.



Suggested R.T.A. driver: CSD Series, NDC Series, HGD Series.

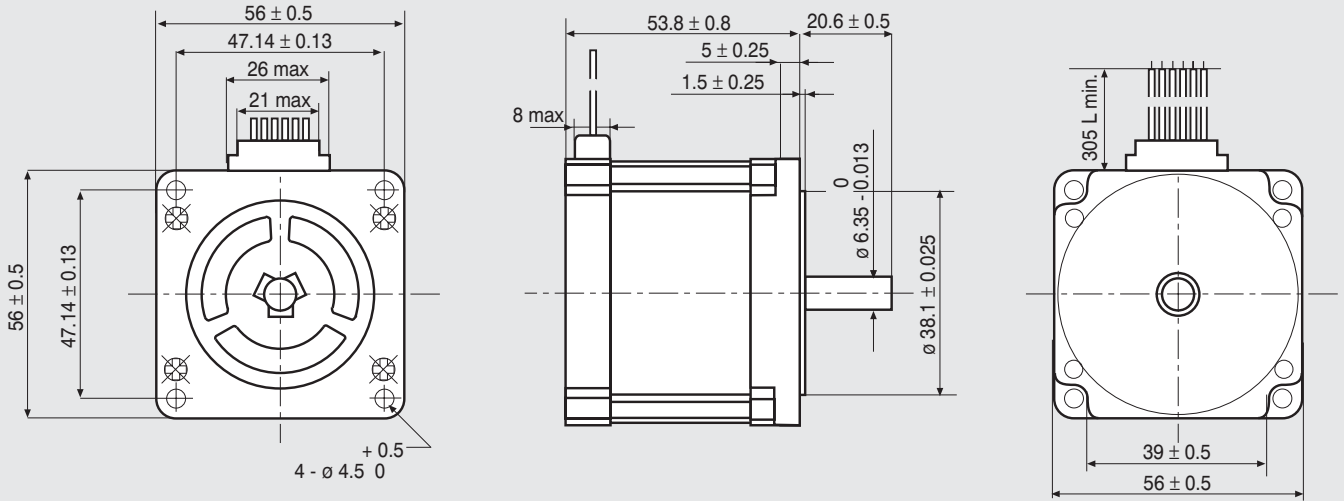

Dimensions in mm.

FEATURES CARATTERISTICHE		
MODEL MODELLO		103 - H7123 - 0440
BASIC STEP ANGLE		$1.8^\circ \pm 0.09^\circ$
BIPOLAR CURRENT	(Amp)	1.5 ^(*)
UNIPOLAR CURRENT	(Amp)	2
RESISTANCE	(Ohm)	1.6
INDUCTANCE	(mH)	3.8
BIPOLAR HOLDING TORQUE	(Ncm)	110
UNIPOLAR HOLDING TORQUE	(Ncm)	85
ROTOR INERTIA	(Kg $m^2 \times 10^{-7}$)	210
THEORETICAL ACCELERATION	(rad x sec. $^{-2}$)	50000
BACK E.M.F.	(V/Krpm)	31
MASS	(Kg)	0.65
LEADS CODE		IV

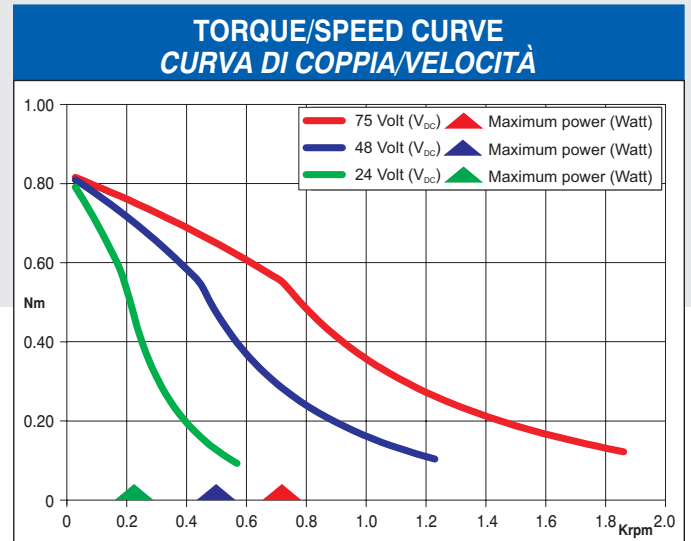

^(*) Bipolar series connection.
^(*) Collegamento bipolare serie.



Suggested R.T.A. driver: CSD Series, NDC Series, HGD Series.

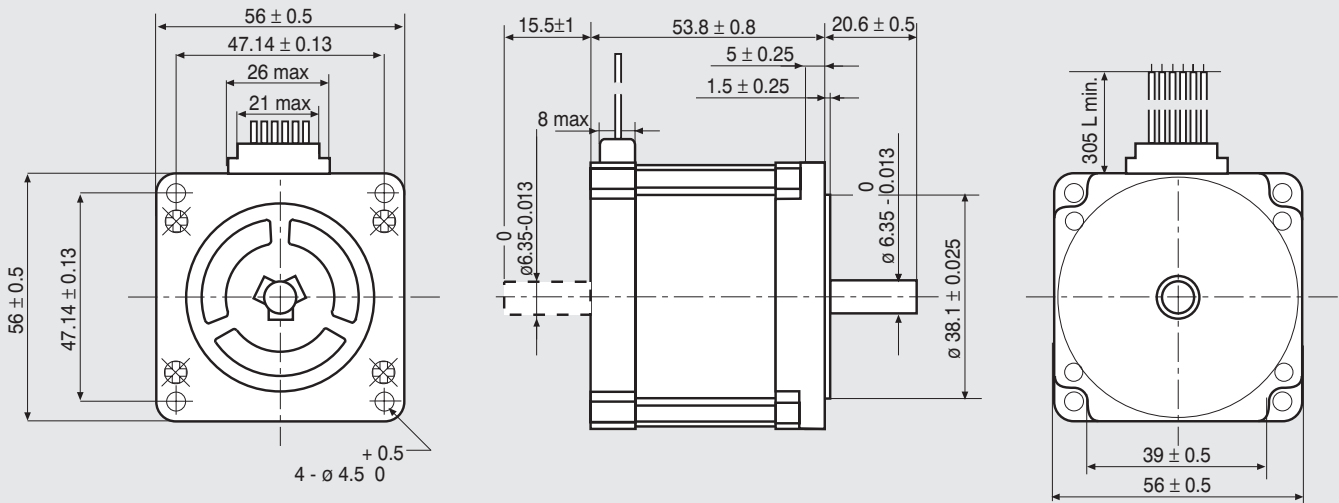

Dimensions in mm.

FEATURES CARATTERISTICHE		
MODEL MODELLO		103 - H7123 - 5040 (103 - H7123 - 5010)
BASIC STEP ANGLE		$1.8^\circ \pm 0.09^\circ$
BIPOLAR CURRENT	(Amp)	2
UNIPOLAR CURRENT	(Amp)	
RESISTANCE	(Ohm)	0.8
INDUCTANCE	(mH)	3.8
BIPOLAR HOLDING TORQUE	(Ncm)	85
UNIPOLAR HOLDING TORQUE	(Ncm)	
ROTOR INERTIA	($\text{Kgm}^2 \times 10^{-7}$)	210
THEORETICAL ACCELERATION	($\text{rad} \times \text{sec.}^{-2}$)	38500
BACK E.M.F.	(V/Krpm)	31
MASS	(Kg)	0.65
LEADS CODE		V

Codes between brackets refer to double shaft models.
Le sigle fra parentesi si riferiscono ai modelli bialbero.

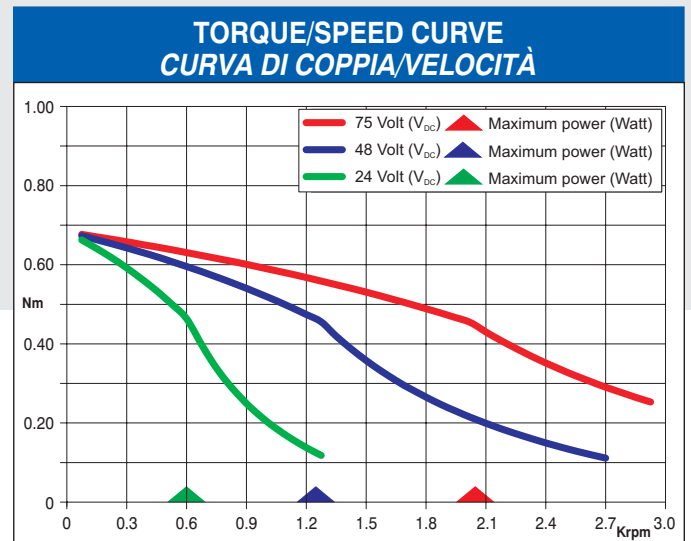

R.T.A. s.r.l. PAVIA (ITALY) SANYO DENKI CO., Ltd (JAPAN)



Suggested R.T.A. driver: CSD Series, NDC Series, HGD Series.

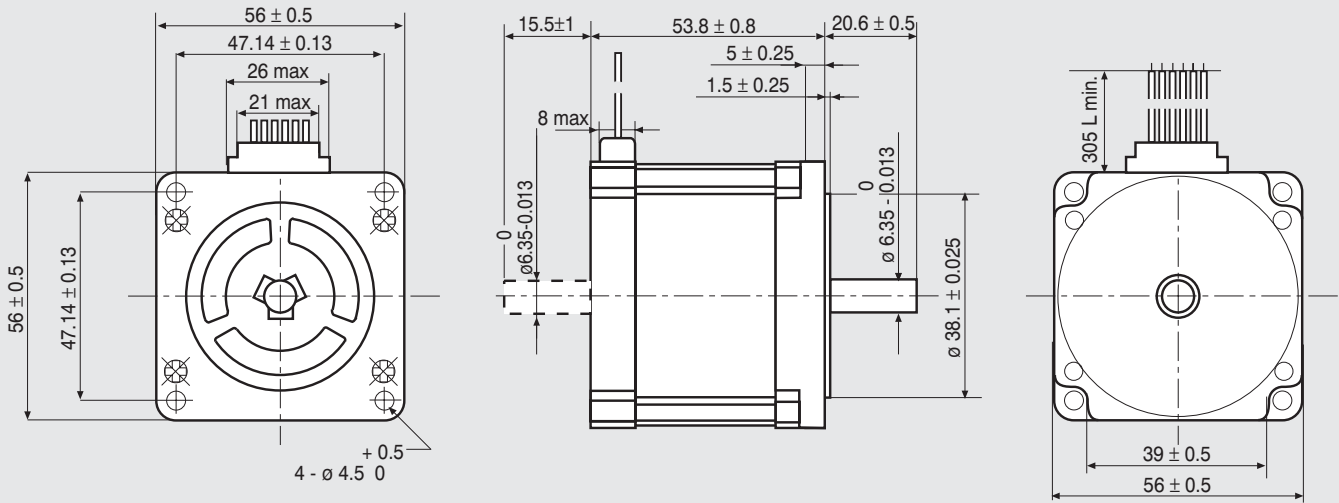

Dimensions in mm.

FEATURES CARATTERISTICHE		
MODEL MODELLO		103 - H7123 - 0740 (103 - H7123 - 0710)
BASIC STEP ANGLE		$1.8^\circ \pm 0.09^\circ$
BIPOLAR CURRENT	(Amp)	2.2 ^(*)
UNIPOLAR CURRENT	(Amp)	3
RESISTANCE	(Ohm)	0.77
INDUCTANCE	(mH)	1.6
BIPOLAR HOLDING TORQUE	(Ncm)	110
UNIPOLAR HOLDING TORQUE	(Ncm)	85
ROTOR INERTIA	(Kg $m^2 \times 10^{-7}$)	210
THEORETICAL ACCELERATION	(rad x sec. $^{-2}$)	50000
BACK E.M.F.	(V/Krpm)	20
MASS	(Kg)	0.65
LEADS CODE		IV

Codes between brackets refer to double shaft models.
Le sigle fra parentesi si riferiscono ai modelli bialbero.

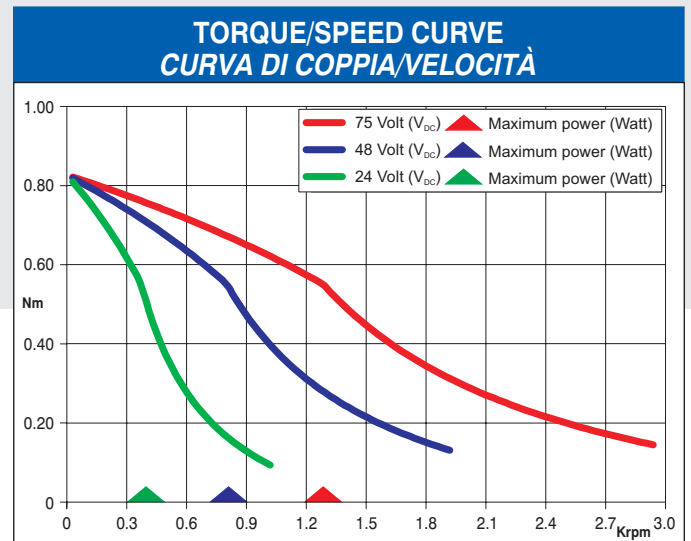

^(*) Bipolar series connection.
^(*) Collegamento bipolare serie.



Suggested R.T.A. driver: CSD Series, NDC Series, HGD Series.

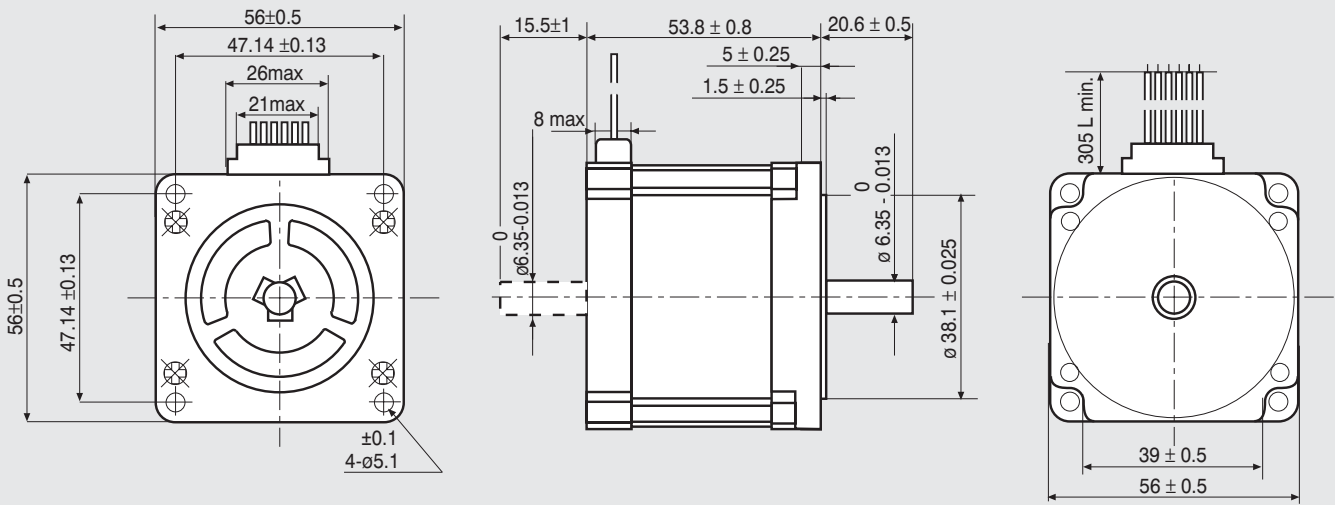

Dimensions in mm.

FEATURES CARATTERISTICHE		103 - H7123 - 1749 (103 - H7123 - 1710)
BASIC STEP ANGLE		1.8° ± 0.09°
BIPOLAR CURRENT	(Amp)	4
UNIPOLAR CURRENT	(Amp)	
RESISTANCE	(Ohm)	0.41
INDUCTANCE	(mH)	1.6
BIPOLAR HOLDING TORQUE	(Ncm)	110
UNIPOLAR HOLDING TORQUE	(Ncm)	
ROTOR INERTIA	(Kg ^m 2 x 10 ⁻⁷)	210
THEORETICAL ACCELERATION	(rad x sec. ⁻²)	50000
BACK E.M.F.	(V/Krpm)	20
MASS	(Kg)	0.65
LEADS CODE		V

Codes between brackets refer to double shaft models.
Le sigle fra parentesi si riferiscono ai modelli bialbero.

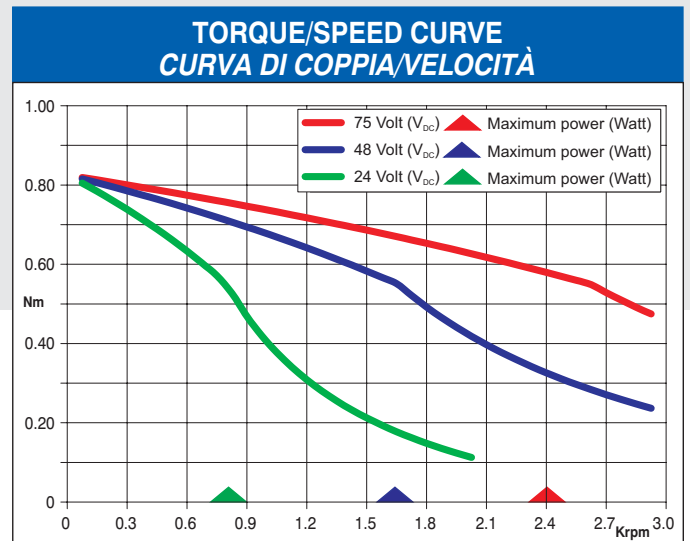

R.T.A. s.r.l. PAVIA (ITALY) SANYO DENKI CO., Ltd (JAPAN)



Suggested R.T.A. driver: CSD Series, NDC Series, HGD Series, PLUS Series.

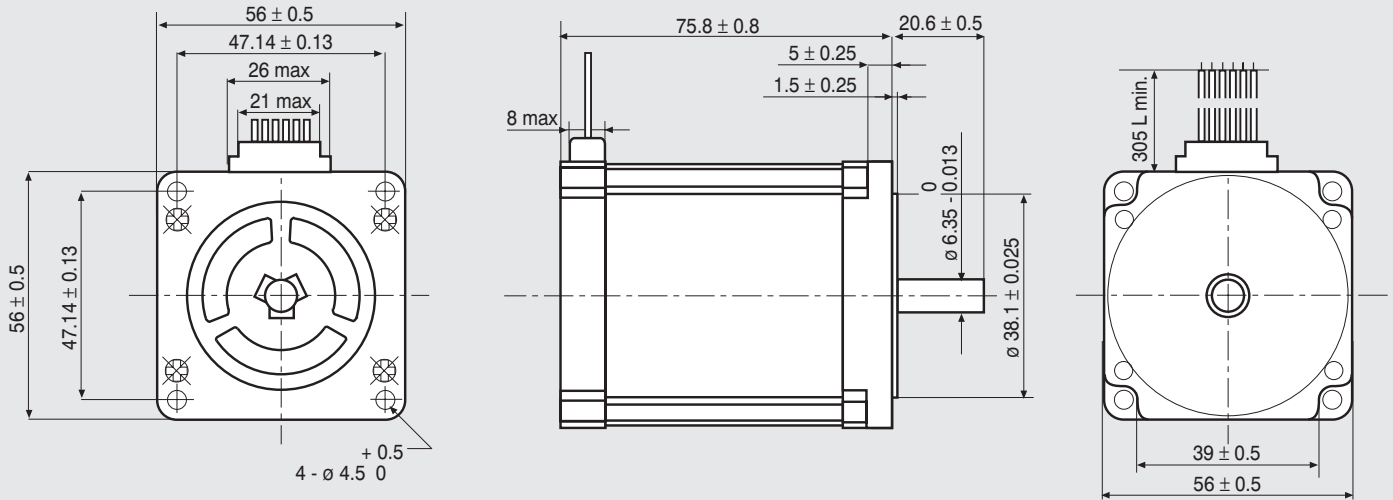

Dimensions in mm.

FEATURES
CARATTERISTICHE

MODEL MODELLO	103 - H7126 - 0140	
BASIC STEP ANGLE		$1.8^\circ \pm 0.09^\circ$
BIPOLAR CURRENT	(Amp)	0.75 ^(*)
UNIPOLAR CURRENT	(Amp)	1
RESISTANCE	(Ohm)	8.6
INDUCTANCE	(mH)	19
BIPOLAR HOLDING TORQUE	(Ncm)	165
UNIPOLAR HOLDING TORQUE	(Ncm)	130
ROTOR INERTIA	(Kg $\text{m}^2 \times 10^{-7}$)	360
THEORETICAL ACCELERATION	(rad x sec. $^{-2}$)	45800
BACK E.M.F.	(V/Krpm)	92
MASS	(Kg)	1
LEADS CODE		IV

TORQUE/SPEED CURVE
CURVA DI COPPIA/VELOCITÀ

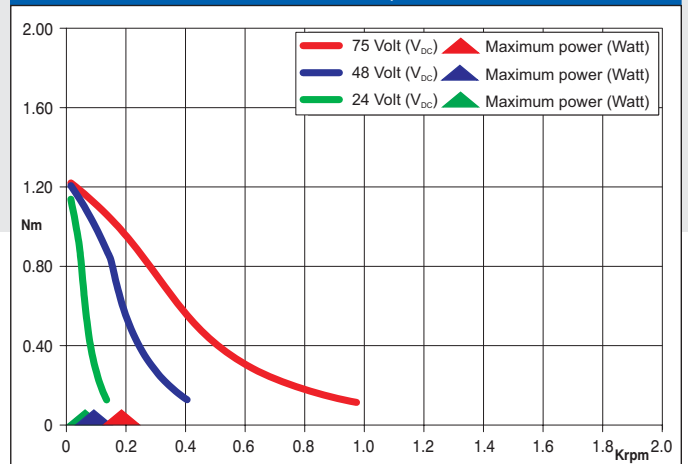

^(*) Bipolar series connection.
^(*) Collegamento bipolare serie.



Suggested R.T.A. driver: CSD Series, NDC Series, HGD Series.

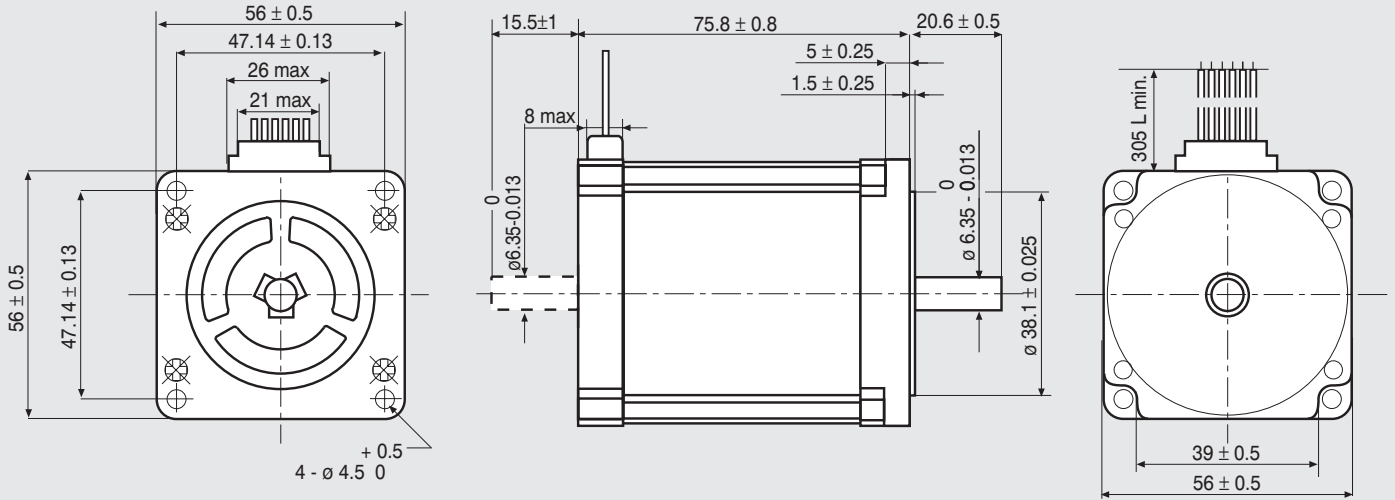

Dimensions in mm.

**FEATURES
CARATTERISTICHE**

MODEL MODELLO	103 - H7126 - 0740 (103 - H7126 - 0710)	
BASIC STEP ANGLE	$1.8^\circ \pm 0.09^\circ$	
BIPOLAR CURRENT	(Amp)	2.2 ^(*)
UNIPOLAR CURRENT	(Amp)	3
RESISTANCE	(Ohm)	0.9
INDUCTANCE	(mH)	2.2
BIPOLAR HOLDING TORQUE	(Ncm)	165
UNIPOLAR HOLDING TORQUE	(Ncm)	130
ROTOR INERTIA	(Kgm ² x 10 ⁻⁷)	360
THEORETICAL ACCELERATION	(rad x sec. ⁻²)	45800
BACK E.M.F.	(V/Krpm)	31
MASS	(Kg)	1
LEADS CODE	IV	

Codes between brackets refer to double shaft models.
Le sigle fra parentesi si riferiscono ai modelli bialbero.

**TORQUE/SPEED CURVE
CURVA DI COPPIA/VELOCITÀ**

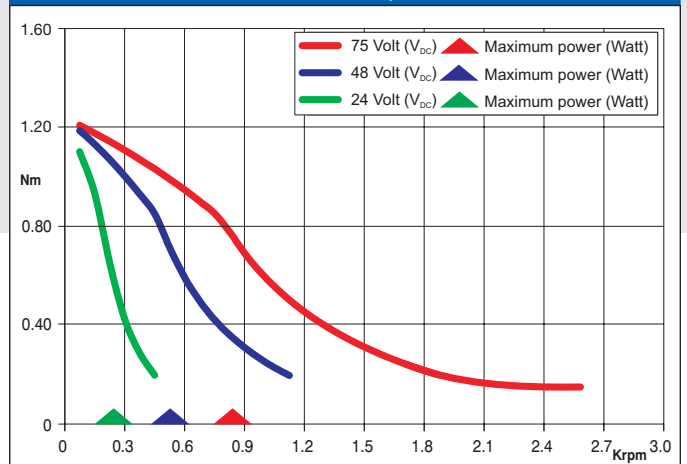

^(*) Bipolar series connection.
^(*) Collegamento bipolare serie.



Suggested R.T.A. driver: CSD Series, NDC Series, HGD Series.

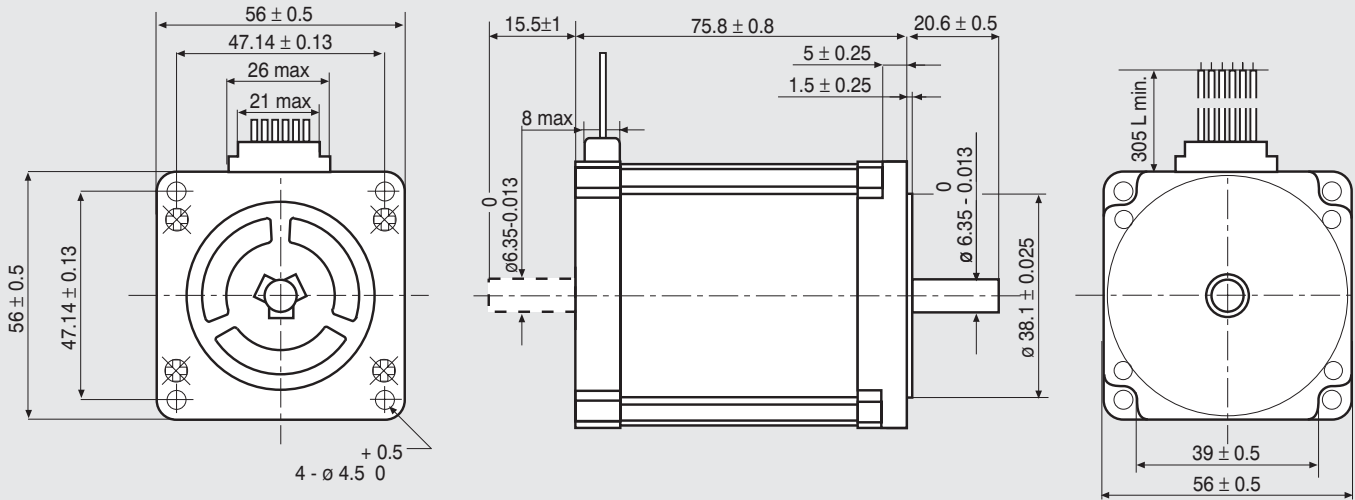

Dimensions in mm.

FEATURES
CARATTERISTICHE

MODEL MODELLO	103 - H7126 - 1740 (103 - H7126 - 1710)	
BASIC STEP ANGLE	$1.8^\circ \pm 0.09^\circ$	
BIPOLAR CURRENT	(Amp)	4
UNIPOLAR CURRENT	(Amp)	
RESISTANCE	(Ohm)	0.48
INDUCTANCE	(mH)	2.2
BIPOLAR HOLDING TORQUE	(Ncm)	165
UNIPOLAR HOLDING TORQUE	(Ncm)	
ROTOR INERTIA	($\text{Kg} \cdot \text{m}^2 \times 10^{-7}$)	360
THEORETICAL ACCELERATION	($\text{rad} \times \text{sec.}^{-2}$)	45800
BACK E.M.F.	(V/Krpm)	31
MASS	(Kg)	1
LEADS CODE	V	

Codes between brackets refer to double shaft models.
Le sigle fra parentesi si riferiscono ai modelli bialbero.

TORQUE/SPEED CURVE
CURVA DI COPPIA/VELOCITÀ

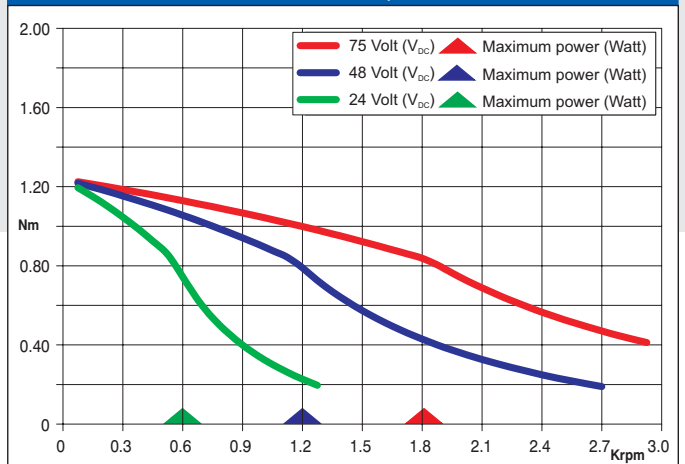

R.T.A. s.r.l. PAVIA (ITALY) SANYO DENKI CO., Ltd (JAPAN)



Suggested R.T.A. driver: CSD Series, NDC Series, HGD Series, PLUS Series.

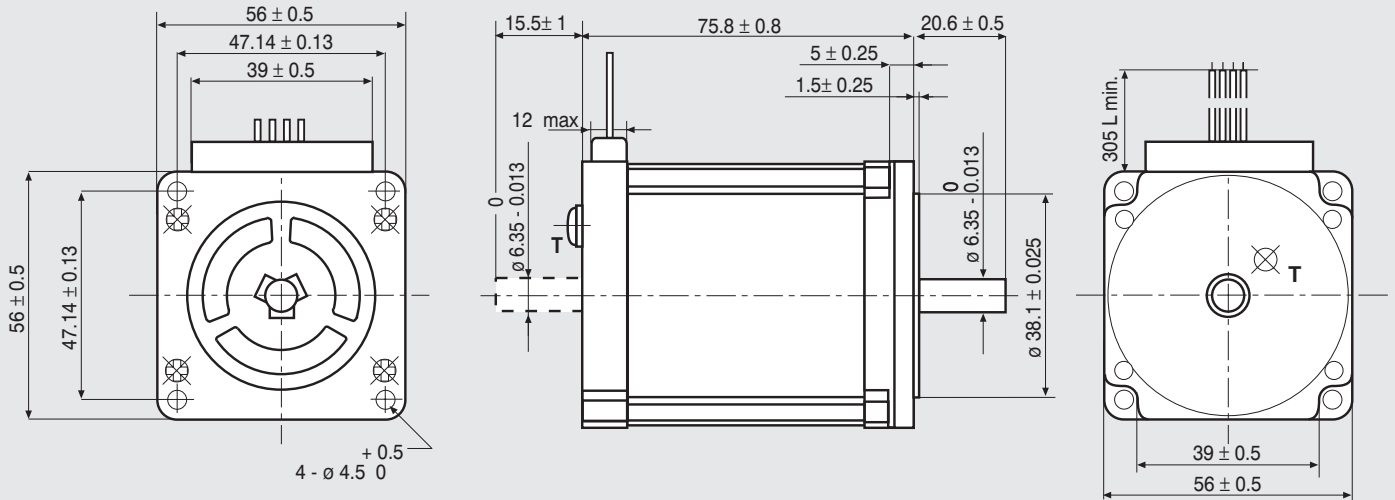

T IS THE EARTH TERMINAL.

Dimensions in mm.

FEATURES CARATTERISTICHE		
MODEL MODELLO		103 - H7126 - 6640 (103 - H7126 - 6610)
BASIC STEP ANGLE		1.8° ± 0.09°
BIPOLAR CURRENT	(Amp)	5.6
UNIPOLAR CURRENT	(Amp)	
RESISTANCE	(Ohm)	0.3
INDUCTANCE	(mH)	0.85
BIPOLAR HOLDING TORQUE	(Ncm)	165
UNIPOLAR HOLDING TORQUE	(Ncm)	
ROTOR INERTIA	(Kgm ² x 10 ⁻⁷)	360
THEORETICAL ACCELERATION	(rad x sec. ⁻²)	45800
BACK E.M.F.	(V/Krpm)	23
MASS	(Kg)	1
PROTECTION DEGREE		IP43
LEADS CODE		V

Codes between brackets refer to double shaft models.
Le sigle fra parentesi si riferiscono ai modelli bialbero.

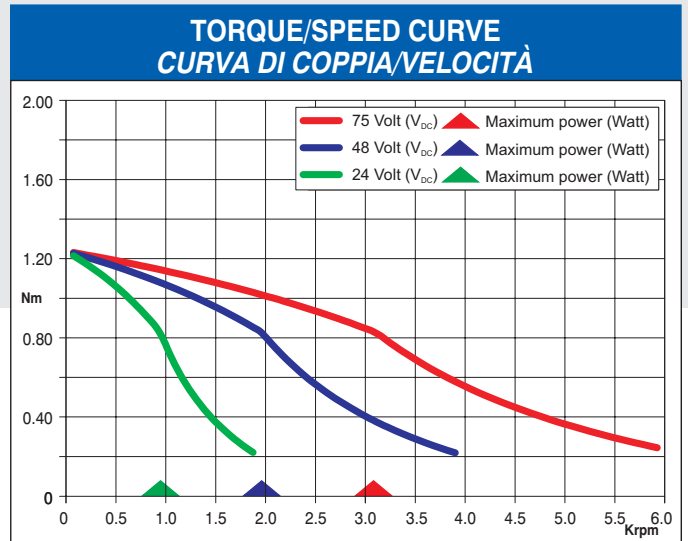

R.T.A. s.r.l. PAVIA (ITALY) SANYO DENKI CO., Ltd (JAPAN)



Suggested R.T.A. driver: NDC Series, HGD Series, PLUS Series.

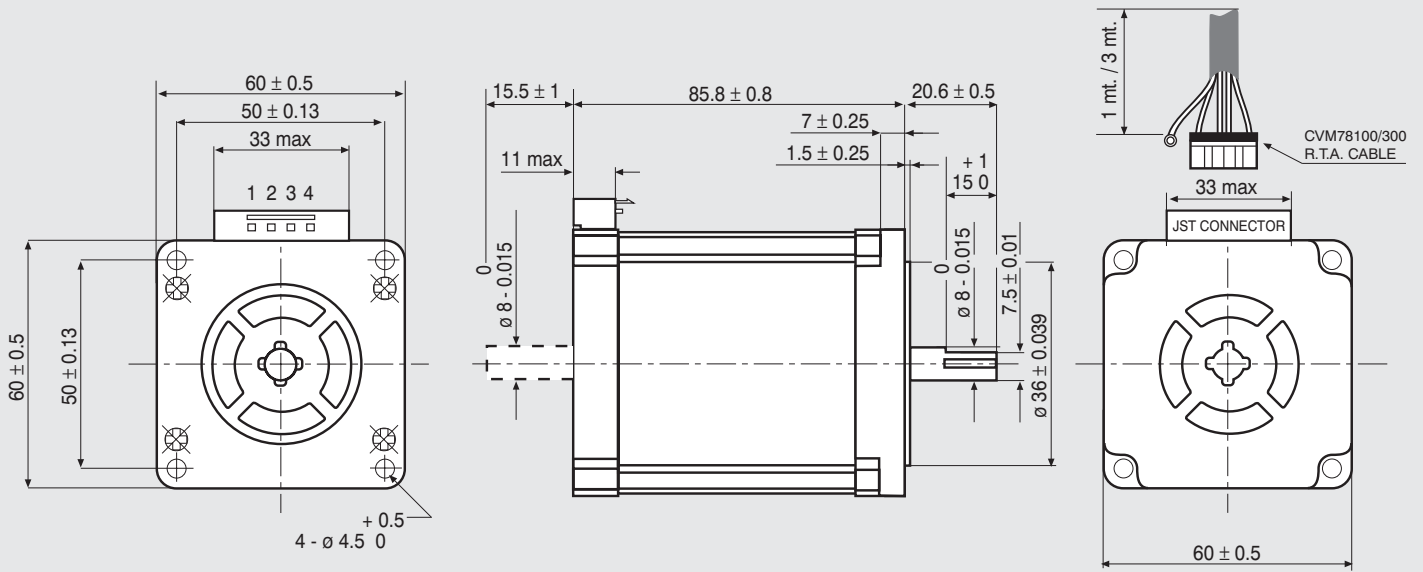

MOTOR CONNECTOR IS JST mod. B4P-VH 4 POLES MALE.
FOR CONNECTION USE JST mod. VHR-4N FEMALE CONNECTOR AND mod. SVH-21T-P1.1 CONTACTS.
NOTE: 103-H7823-1740 MOTORS NEED CVM78100 AND CVM78300 R.T.A. CABLES. CONTACT R.T.A. FOR FURTHER DETAILS.

Dimensions in mm.

FEATURES CARATTERISTICHE		
MODEL MODELLO		103 - H7823 - 1740 (103 - H7823 - 1714)
BASIC STEP ANGLE		1.8° ± 0.09°
BIPOLAR CURRENT	(Amp)	4.0
UNIPOLAR CURRENT	(Amp)	
RESISTANCE	(Ohm)	0.65
INDUCTANCE	(mH)	2.4
BIPOLAR HOLDING TORQUE	(Ncm)	300
UNIPOLAR HOLDING TORQUE	(Ncm)	
ROTOR INERTIA	(Kgm ² x 10 ⁻⁷)	840
THEORETICAL ACCELERATION	(rad x sec. ⁻²)	35700
BACK E.M.F.	(V/Krpm)	75
MASS	(Kg)	1.4
LEADS CODE		V

Codes between brackets refer to double shaft models.
Le sigle fra parentesi si riferiscono ai modelli bialbero.

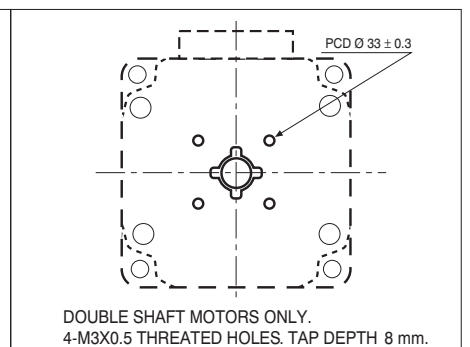
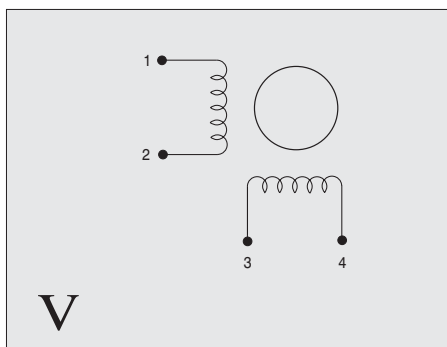
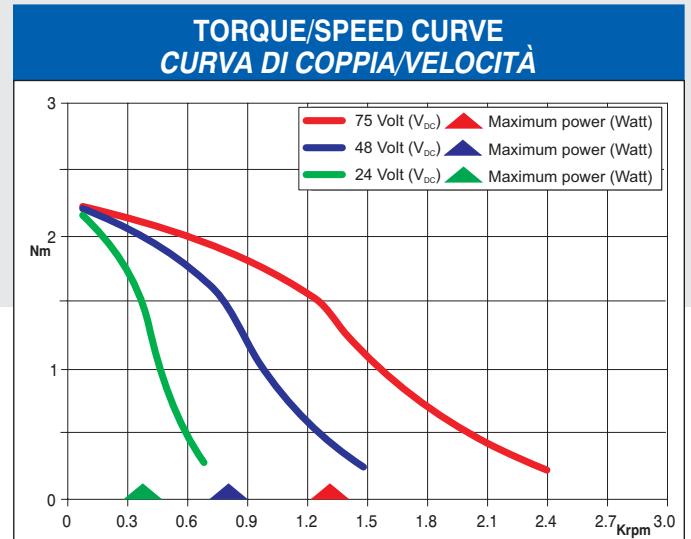

Suggested R.T.A. driver: CSD Series, NDC Series, HGD Series, PLUS Series.

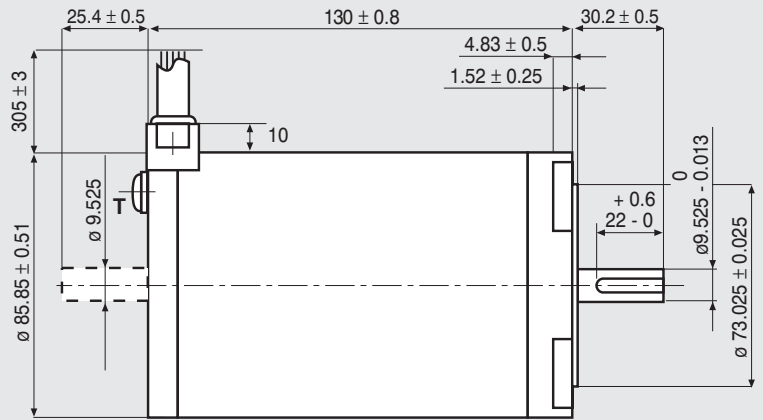
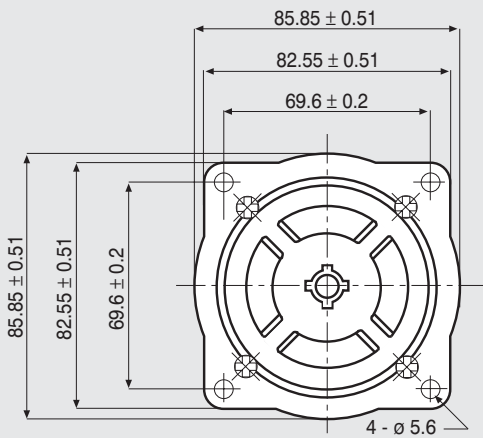

WIRES ARE HOUSED IN A VINYL TUBE.
T IS THE EARTH TERMINAL.

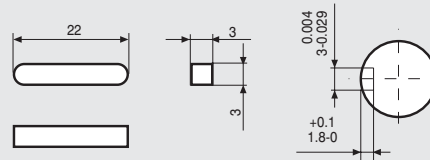

Dimensions in mm.

FEATURES CARATTERISTICHE		MODEL MODELLO	103 - 845 - 6741 (103 - 845 - 6711)
BASIC STEP ANGLE			1.8° ± 0.09°
BIPOLAR CURRENT	(Amp)		9.5 ^(*)
UNIPOLAR CURRENT	(Amp)		6.7
RESISTANCE	(Ohm)		0.45
INDUCTANCE	(mH)		2.0
BIPOLAR HOLDING TORQUE	(Ncm)		510
UNIPOLAR HOLDING TORQUE	(Ncm)		410
ROTOR INERTIA	(Kgm ² x 10 ⁻⁷)		1550
THEORETICAL ACCELERATION	(rad x sec. ⁻²)		32900
BACK E.M.F.	(V/Krpm)		46
MASS	(Kg)		3.6
PROTECTION DEGREE			IP43
LEADS CODE			II

Codes between brackets refer to double shaft models.
Le sigle fra parentesi si riferiscono ai modelli bialbero.

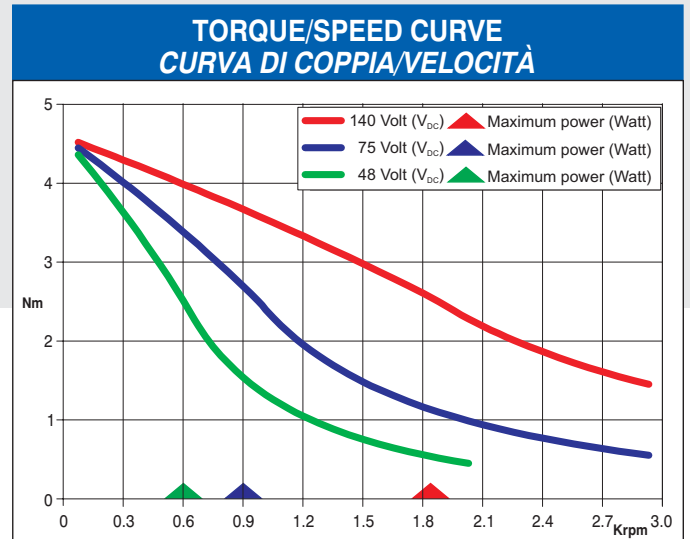

^(*) Bipolar parallel connection.
^(*) Collegamento bipolare parallelo.



Suggested R.T.A. driver: PLUS Series, contact R.T.A.

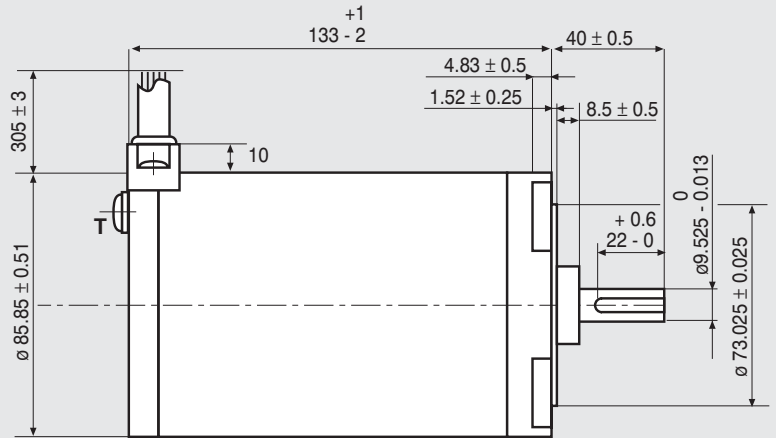
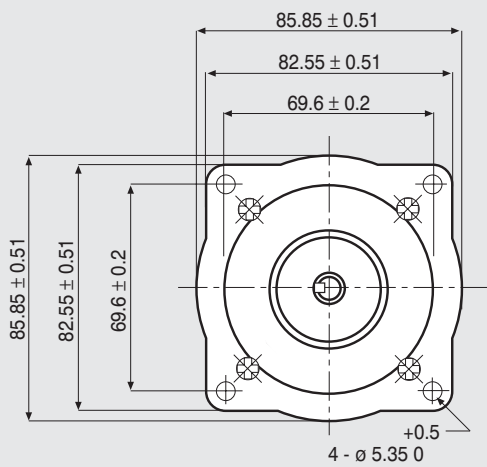

WIRES ARE HOUSED IN A VINYL TUBE.
T IS THE EARTH TERMINAL.

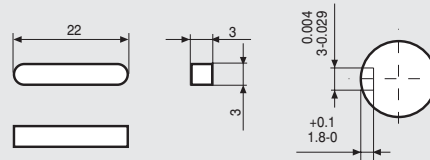

Dimensions in mm.

FEATURES CARATTERISTICHE		MODEL MODELLO	103 - 845 - 67S1
BASIC STEP ANGLE			1.8° ± 0.09°
BIPOLAR CURRENT	(Amp)		9.5 ^(*)
UNIPOLAR CURRENT	(Amp)		6.7
RESISTANCE	(Ohm)		0.45
INDUCTANCE	(mH)		2.0
BIPOLAR HOLDING TORQUE	(Ncm)		510
UNIPOLAR HOLDING TORQUE	(Ncm)		410
ROTOR INERTIA	(Kgm ² x 10 ⁻⁷)		1550
THEORETICAL ACCELERATION	(rad x sec. ⁻²)		32900
BACK E.M.F.	(V/Krpm)		46
MASS	(Kg)		3.6
PROTECTION DEGREE			IP55
LEADS CODE			II

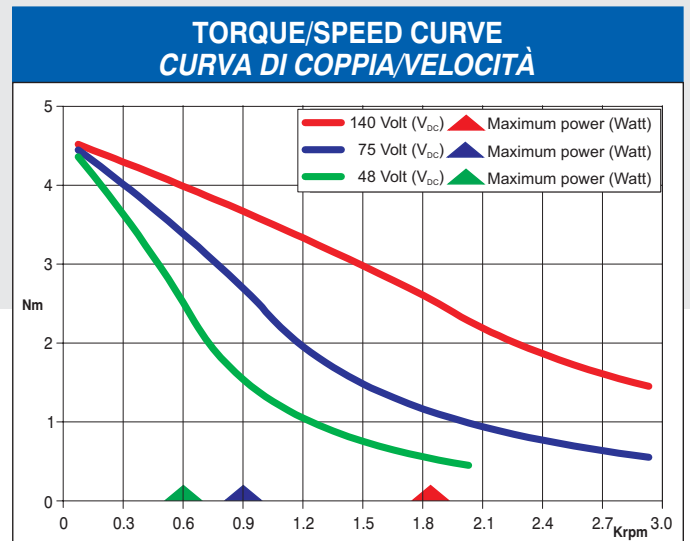

^(*) Bipolar parallel connection.
^(*) Collegamento bipolare parallelo.

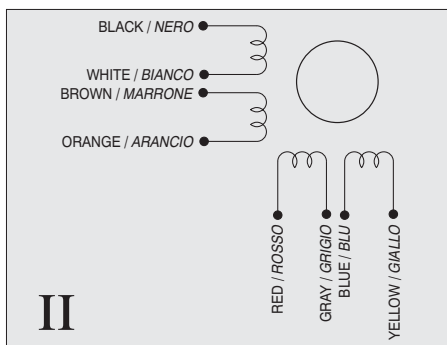

Suggested R.T.A. driver: PLUS Series, contact R.T.A.

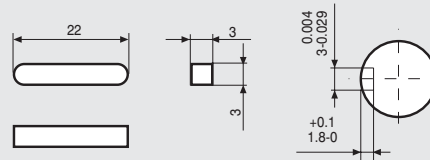
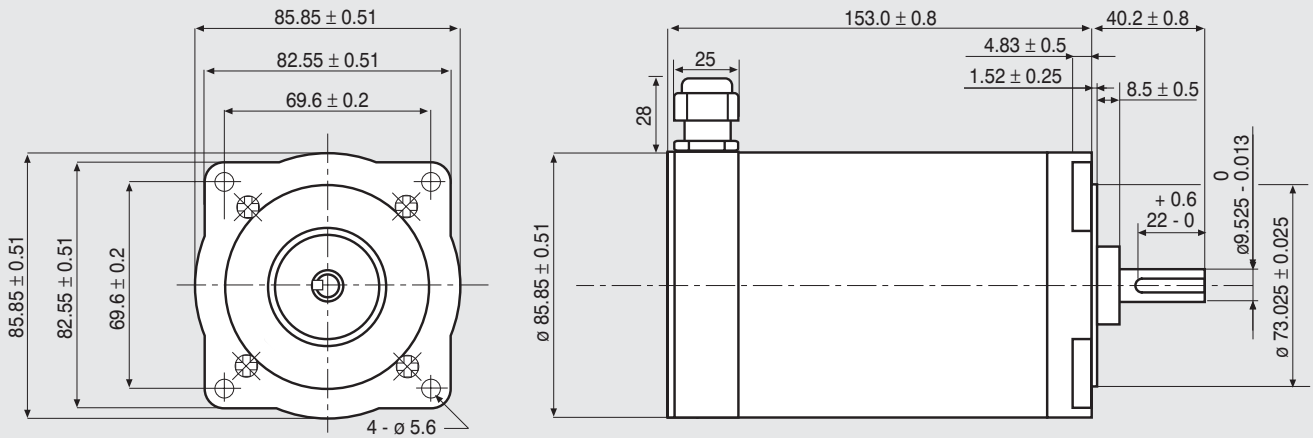

Dimensions in mm.

FEATURES CARATTERISTICHE		MODEL MODELLO	103 - 845 - 67S41
BASIC STEP ANGLE			1.8° ± 0.09°
BIPOLAR CURRENT	(Amp)		9.5 ^(*)
UNIPOLAR CURRENT	(Amp)		6.7
RESISTANCE	(Ohm)		0.45
INDUCTANCE	(mH)		2.0
BIPOLAR HOLDING TORQUE	(Ncm)		510
UNIPOLAR HOLDING TORQUE	(Ncm)		410
ROTOR INERTIA	(Kgm ² x 10 ⁻⁷)		1550
THEORETICAL ACCELERATION	(rad x sec. ⁻²)		32900
BACK E.M.F.	(V/Krpm)		46
MASS	(Kg)		3.9
PROTECTION DEGREE			IP55
LEADS CODE			VI

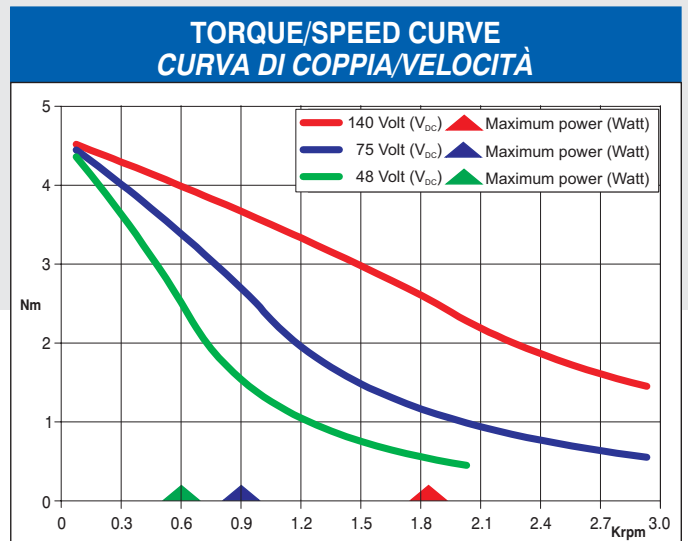

^(*) Bipolar parallel connection.
^(*) Collegamento bipolare parallelo.

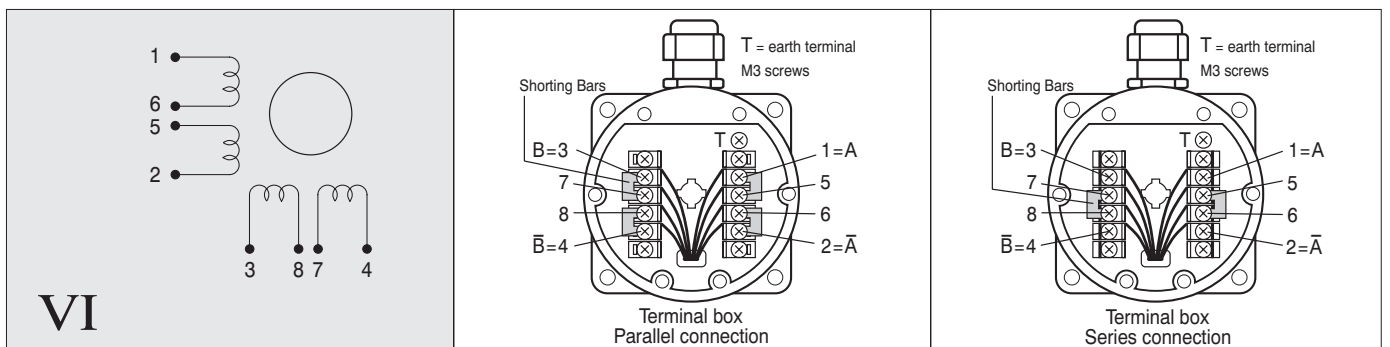

Suggested R.T.A. driver: PLUS Series, contact R.T.A.

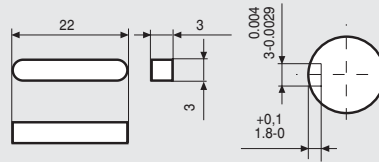
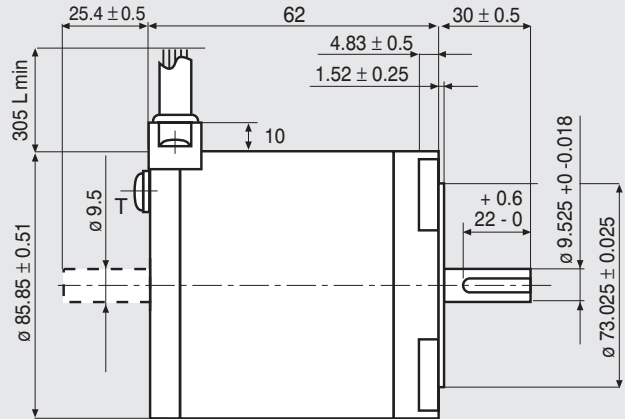
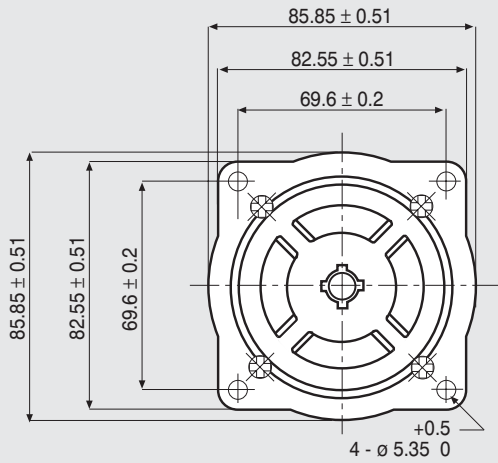

WIRES ARE HOUSED IN A VINYL TUBE.
T IS THE EARTH TERMINAL.

Dimensions in mm.

FEATURES CARATTERISTICHE		MODEL MODELLO	103 - H8221 - 6241 (103 - H8221 - 6211)
BASIC STEP ANGLE			1.8° ± 0.09°
BIPOLAR CURRENT	(Amp)		6
UNIPOLAR CURRENT	(Amp)		
RESISTANCE	(Ohm)		0.3
INDUCTANCE	(mH)		1.65
BIPOLAR HOLDING TORQUE	(Ncm)		300
UNIPOLAR HOLDING TORQUE	(Ncm)		
ROTOR INERTIA	(Kgm ² x 10 ⁻⁷)		1450
THEORETICAL ACCELERATION	(rad x sec. ⁻²)		20600
BACK E.M.F.	(V/Krpm)		50
MASS	(Kg)		1.5
PROTECTION DEGREE			IP43
LEADS CODE			V

Codes between brackets refer to double shaft models.
Le sigle fra parentesi si riferiscono ai modelli bialbero.

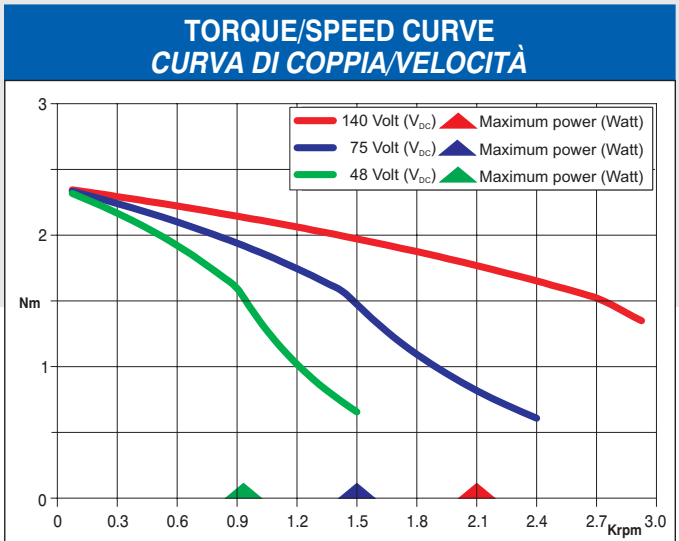

Suggested R.T.A. driver: NDC Series, HGD Series, PLUS Series.

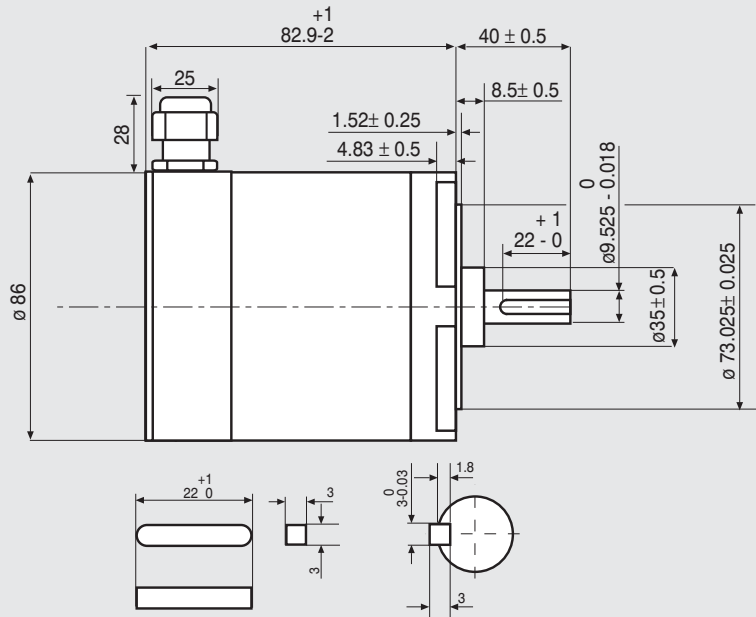
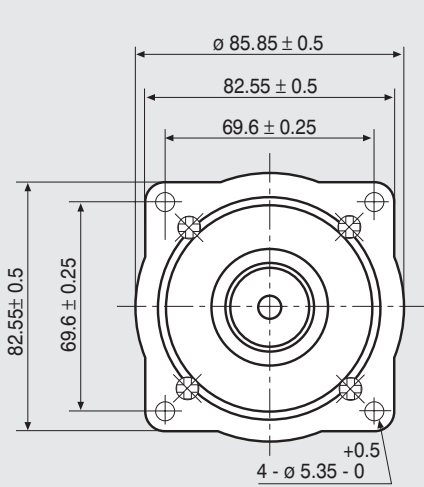

Dimensions in mm.

FEATURES CARATTERISTICHE		MODEL MODELLO	103 - H8221 - 62S41
BASIC STEP ANGLE			1.8° ± 0.09°
BIPOLAR CURRENT	(Amp)		6
UNIPOLAR CURRENT	(Amp)		
RESISTANCE	(Ohm)		0.3
INDUCTANCE	(mH)		1.65
BIPOLAR HOLDING TORQUE	(Ncm)		300
UNIPOLAR HOLDING TORQUE	(Ncm)		
ROTOR INERTIA	(Kg ^m 2 x 10 ⁻⁷)		1450
THEORETICAL ACCELERATION	(rad x sec. ⁻²)		20600
BACK E.M.F.	(V/Krpm)		50
MASS	(Kg)		1.75
PROTECTION DEGREE			IP55
LEADS CODE			V

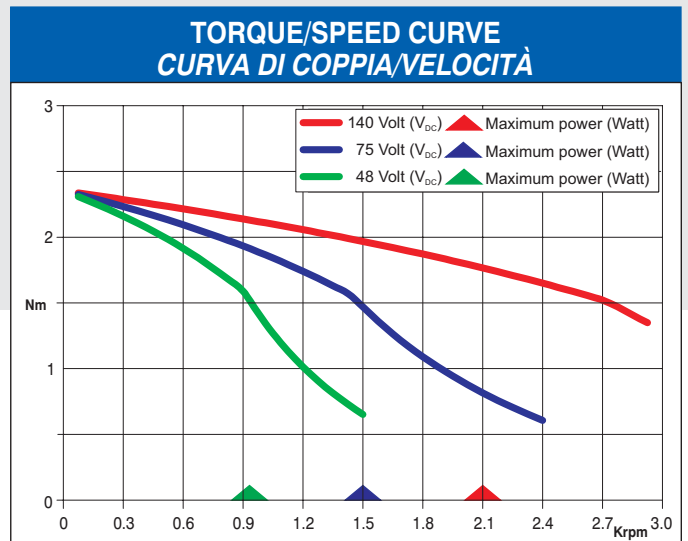

R.T.A. s.r.l. PAVIA (ITALY) SANYO DENKI CO., Ltd (JAPAN)

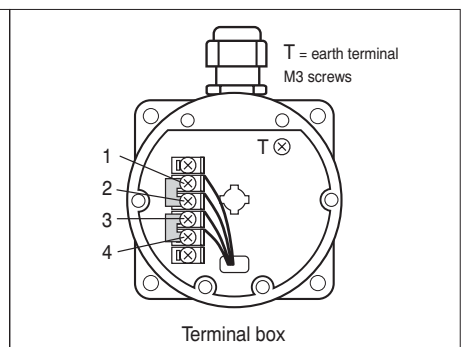
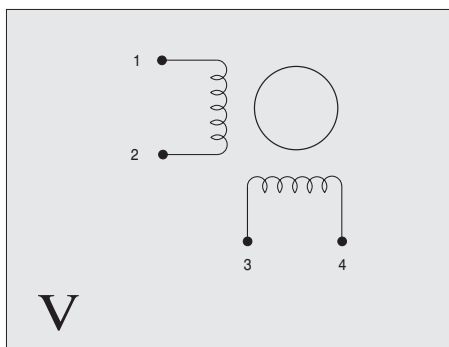

Suggested R.T.A. driver: NDC Series, HGD Series, PLUS Series.

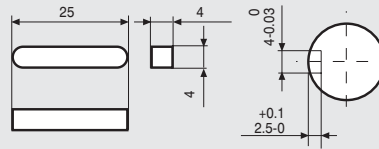
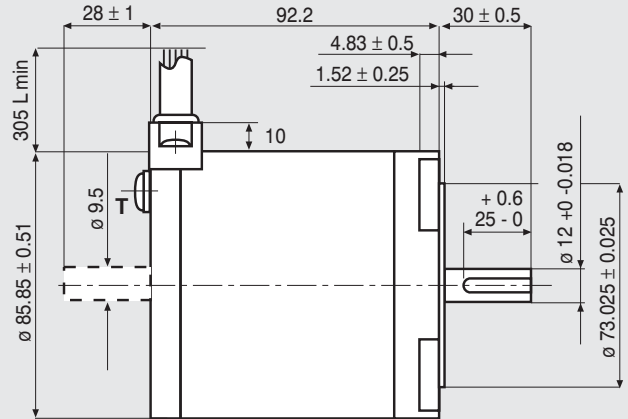
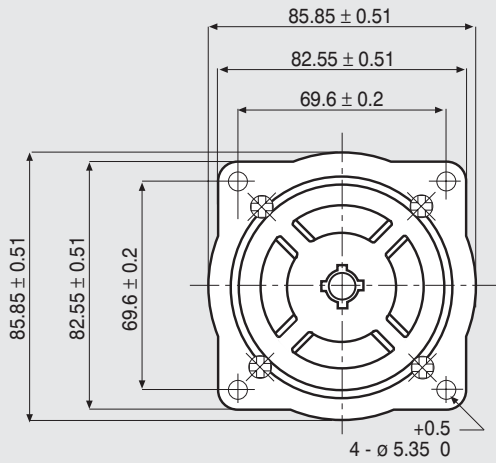

WIRES ARE HOUSED IN A VINYL TUBE.
T IS THE EARTH TERMINAL.

Dimensions in mm.

FEATURES CARATTERISTICHE		MODEL MODELLO	103 - H8222 - 6340 (103 - H8222 - 6310)
BASIC STEP ANGLE			1.8° ± 0.09°
BIPOLAR CURRENT	(Amp)		6
UNIPOLAR CURRENT	(Amp)		
RESISTANCE	(Ohm)		0.35
INDUCTANCE	(mH)		2.7
BIPOLAR HOLDING TORQUE	(Ncm)		560
UNIPOLAR HOLDING TORQUE	(Ncm)		
ROTOR INERTIA	(Kg ^m 2 x 10 ⁻⁷)		2900
THEORETICAL ACCELERATION	(rad x sec. ⁻²)		19300
BACK E.M.F.	(V/Krpm)		93
MASS	(Kg)		2.5
PROTECTION DEGREE			IP43
LEADS CODE			V

Codes between brackets refer to double shaft models.
Le sigle fra parentesi si riferiscono ai modelli bialbero.

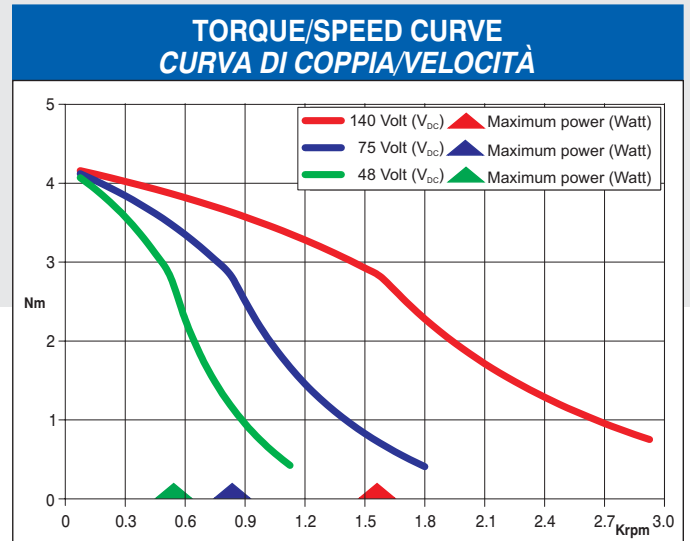

Suggested R.T.A. driver: NDC Series, HGD Series, PLUS Series.

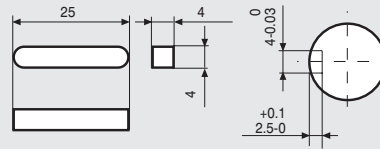
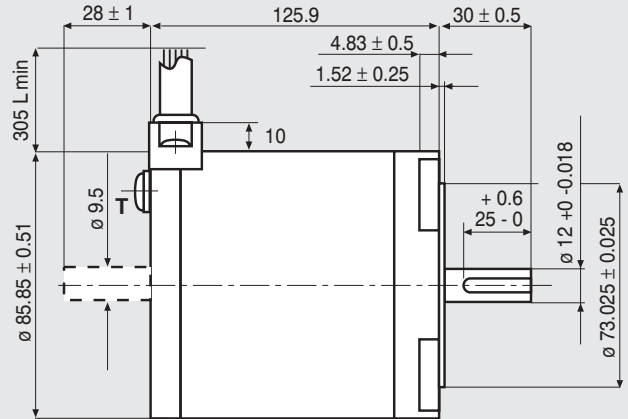
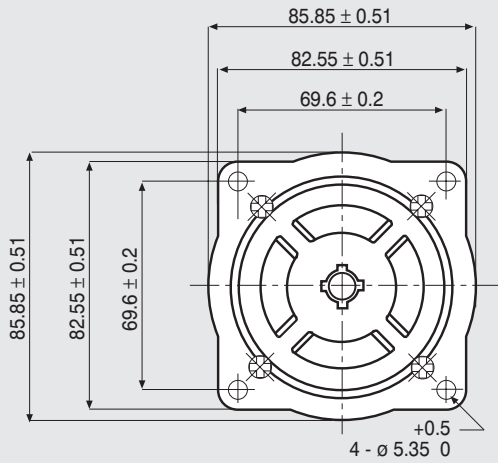

WIRES ARE HOUSED IN A VINYL TUBE.
T IS THE EARTH TERMINAL.

Dimensions in mm.

FEATURES CARATTERISTICHE		MODEL MODELLO	103 - H8223 - 6540 (103 - H8223 - 6510)
BASIC STEP ANGLE			1.8° ± 0.09°
BIPOLAR CURRENT	(Amp)		9
UNIPOLAR CURRENT	(Amp)		
RESISTANCE	(Ohm)		0.2
INDUCTANCE	(mH)		1.4
BIPOLAR HOLDING TORQUE	(Ncm)		790
UNIPOLAR HOLDING TORQUE	(Ncm)		
ROTOR INERTIA	(Kg ^m 2 x 10 ⁻⁷)		4350
THEORETICAL ACCELERATION	(rad x sec. ⁻²)		18200
BACK E.M.F.	(V/Krpm)		88
MASS	(Kg)		3.5
PROTECTION DEGREE			IP43
LEADS CODE			V

Codes between brackets refer to double shaft models.
Le sigle fra parentesi si riferiscono ai modelli bialbero.

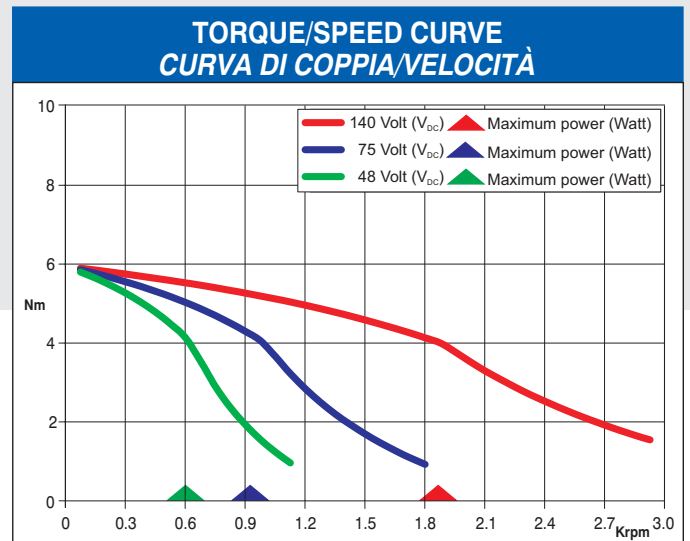

Suggested R.T.A. driver: PLUS Series.

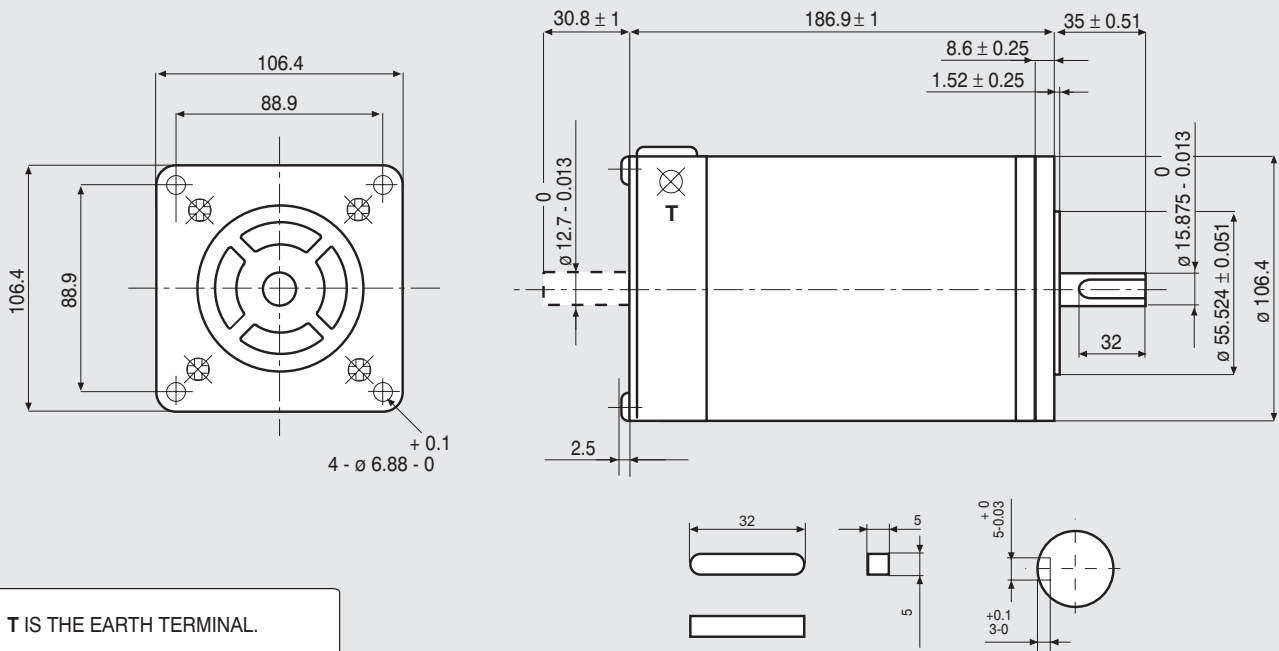

T IS THE EARTH TERMINAL.

Dimensions in mm.

FEATURES CARATTERISTICHE		103 - 8932 - 6451 (103 - 8932 - 6421)
MODEL MODELLO		
BASIC STEP ANGLE		1.8° ± 0.09°
BIPOLAR CURRENT	(Amp)	12.7 ^(*)
UNIPOLAR CURRENT	(Amp)	9
RESISTANCE	(Ohm)	0.28
INDUCTANCE	(mH)	2.4
BIPOLAR HOLDING TORQUE	(Ncm)	1330
UNIPOLAR HOLDING TORQUE	(Ncm)	1020
ROTOR INERTIA	(Kgm ² x 10 ⁻⁷)	8000
THEORETICAL ACCELERATION	(rad x sec. ⁻²)	16500
BACK E.M.F.	(V/Krpm)	85
MASS	(Kg)	7
PROTECTION DEGREE		IP43
LEADS CODE		III

Codes between brackets refer to double shaft models.
Le sigle fra parentesi si riferiscono ai modelli bialbero.

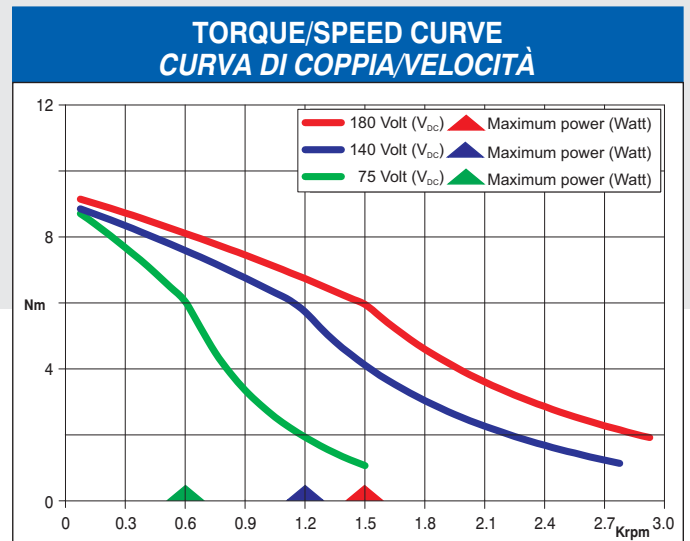

^(*) Bipolar parallel connection.
^(*) Collegamento bipolare parallelo.



Suggested driver: contact R.T.A.

R.T.A. s.r.l. PAVIA (ITALY) SANYO DENKI CO., Ltd (JAPAN)

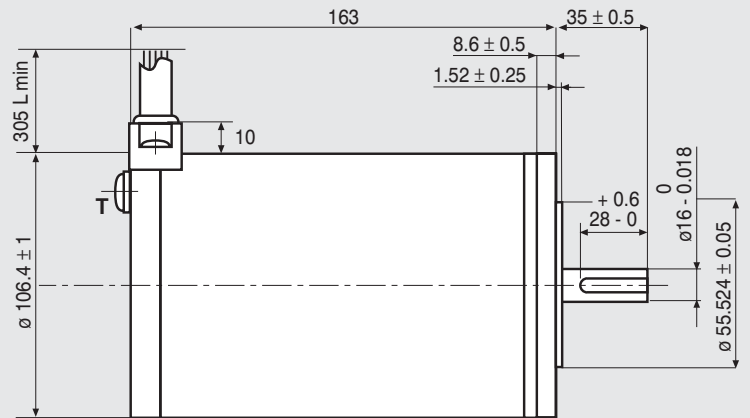
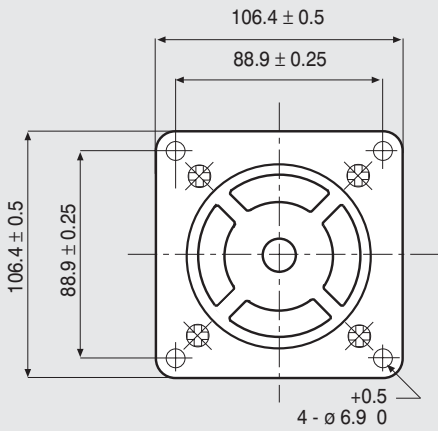

WIRES ARE HOUSED IN A VINYL TUBE.
T IS THE EARTH TERMINAL.

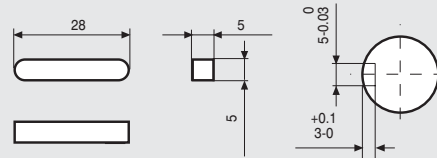

Dimensions in mm.

FEATURES CARATTERISTICHE		MODEL MODELLO	103 - H89222 - 6341
BASIC STEP ANGLE			1.8° ± 0.09°
BIPOLAR CURRENT	(Amp)		6
UNIPOLAR CURRENT	(Amp)		
RESISTANCE	(Ohm)		0.45
INDUCTANCE	(mH)		5.4
BIPOLAR HOLDING TORQUE	(Ncm)		1620
UNIPOLAR HOLDING TORQUE	(Ncm)		
ROTOR INERTIA	(Kgm ² x 10 ⁻⁷)		14650
THEORETICAL ACCELERATION	(rad x sec. ⁻²)		11100
BACK E.M.F.	(V/Krpm)		270
MASS	(Kg)		7
PROTECTION DEGREE			IP43
LEADS CODE			V

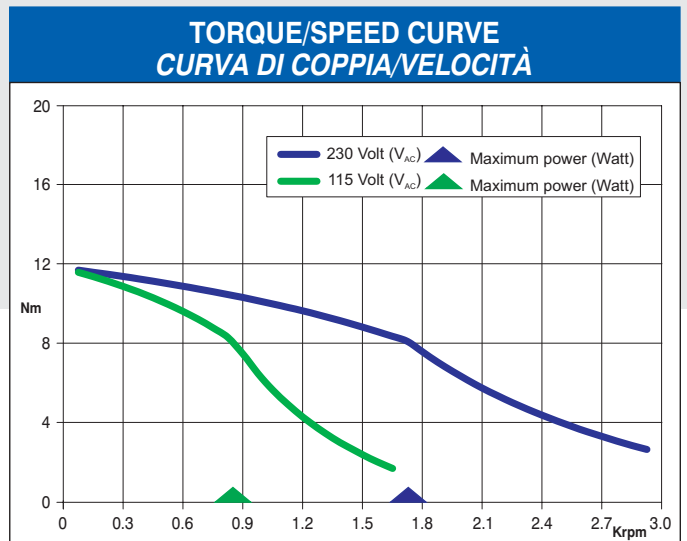

Suggested R.T.A. driver: PLUS Series, X-MIND Series.

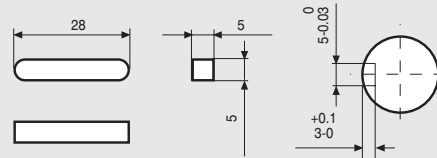
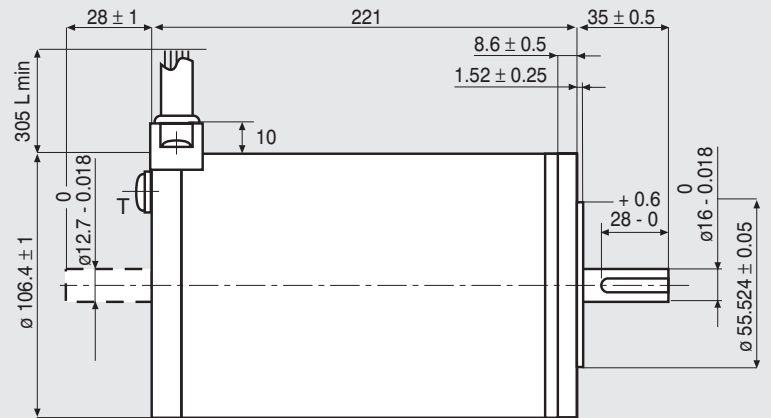
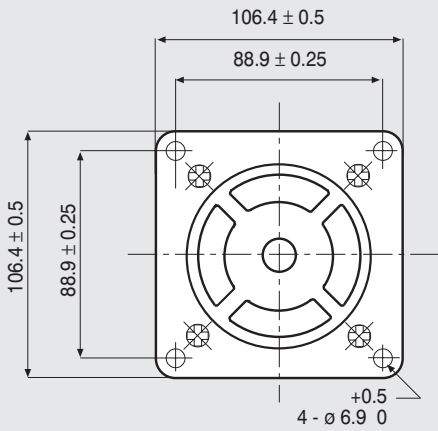

WIRES ARE HOUSED IN A VINYL TUBE.
T IS THE EARTH TERMINAL.

Dimensions in mm.

FEATURES CARATTERISTICHE		
MODEL MODELLO		103 - H89223 - 6341 (103 - H89223 - 6311)
BASIC STEP ANGLE		1.8° ± 0.09°
BIPOLAR CURRENT	(Amp)	6
UNIPOLAR CURRENT	(Amp)	
RESISTANCE	(Ohm)	0.63
INDUCTANCE	(mH)	8
BIPOLAR HOLDING TORQUE	(Ncm)	2460
UNIPOLAR HOLDING TORQUE	(Ncm)	
ROTOR INERTIA	(Kg ^m 2 x 10 ⁻⁷)	22000
THEORETICAL ACCELERATION	(rad x sec. ⁻²)	11100
BACK E.M.F.	(V/Krpm)	410
MASS	(Kg)	10
PROTECTION DEGREE		IP43
LEADS CODE		V

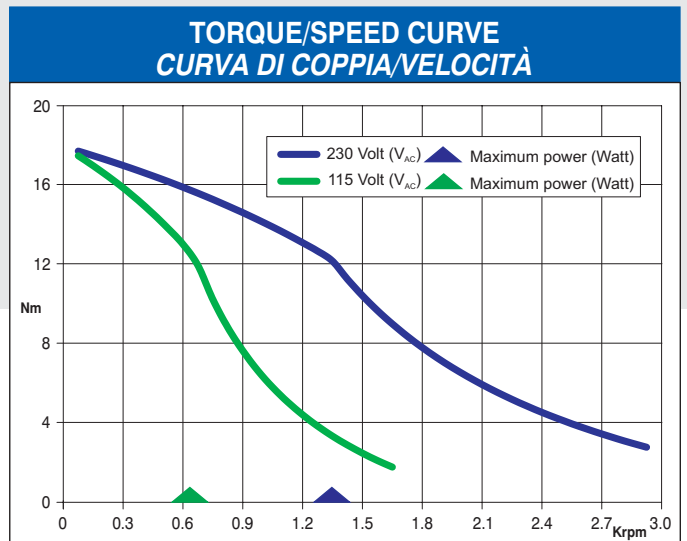

Codes between brackets refer to double shaft models.
Le sigle fra parentesi si riferiscono ai modelli bialbero.



Suggested R.T.A. driver: PLUS Series, X-MIND Series.

R.T.A. s.r.l. PAVIA (ITALY) SANYO DENKI CO., Ltd (JAPAN)

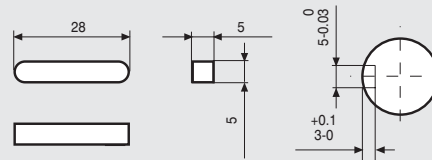
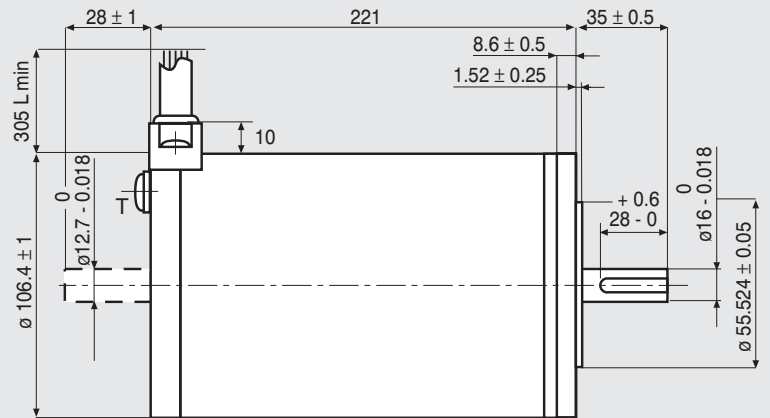
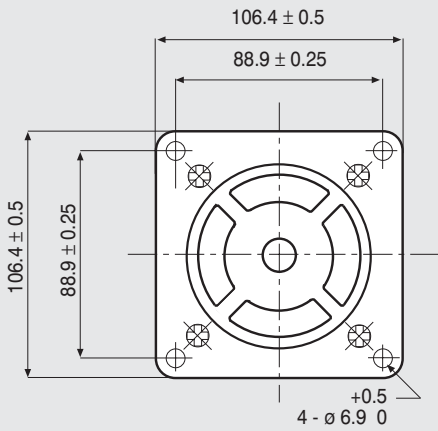

WIRES ARE HOUSED IN A VINYL TUBE.
T IS THE EARTH TERMINAL.

Dimensions in mm.

FEATURES CARATTERISTICHE		
MODEL MODELLO		103 - H89223 - 6641 (103 - H89223 - 6611)
BASIC STEP ANGLE		1.8° ± 0.09°
BIPOLAR CURRENT	(Amp)	12
UNIPOLAR CURRENT	(Amp)	
RESISTANCE	(Ohm)	0.16
INDUCTANCE	(mH)	2
BIPOLAR HOLDING TORQUE	(Ncm)	2460
UNIPOLAR HOLDING TORQUE	(Ncm)	
ROTOR INERTIA	(Kgm ² x 10 ⁻⁷)	22000
THEORETICAL ACCELERATION	(rad x sec. ⁻²)	11100
BACK E.M.F.	(V/Krpm)	205
MASS	(Kg)	10
PROTECTION DEGREE		IP43
LEADS CODE		V

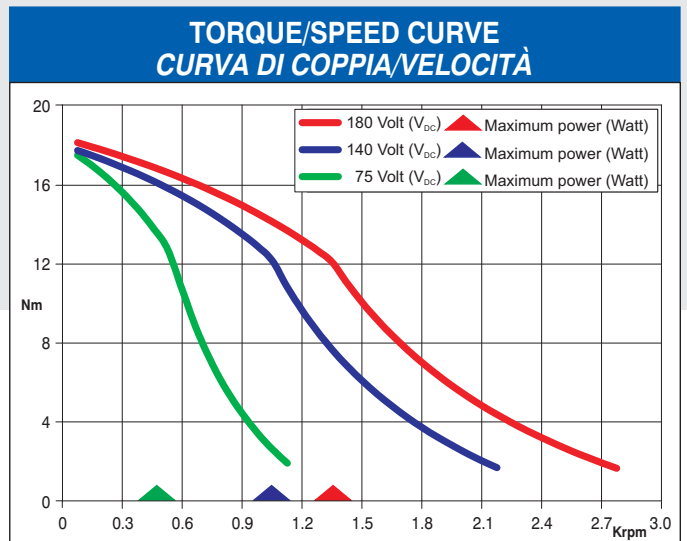

Codes between brackets refer to double shaft models.
Le sigle fra parentesi si riferiscono ai modelli bialbero.



Suggested driver: contact R.T.A.

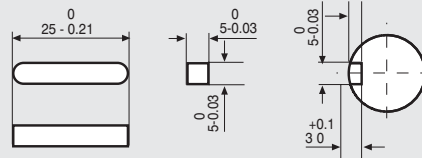
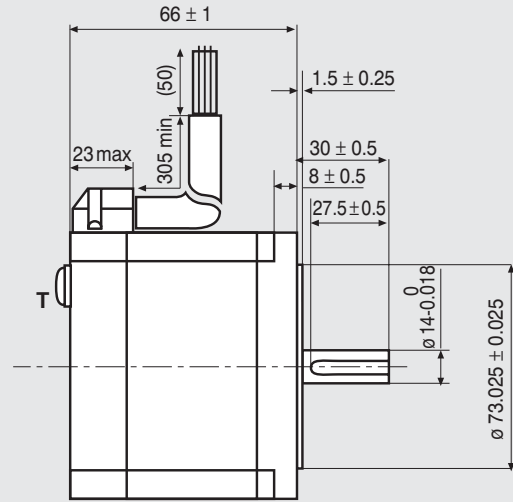
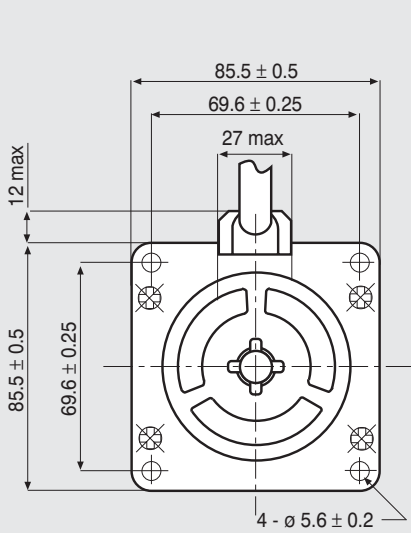

T IS THE EARTH TERMINAL.

Dimensions in mm.

FEATURES CARATTERISTICHE		MODEL MODELLO	SM2861 - 5055
BASIC STEP ANGLE			1.8° ± 0.09°
BIPOLAR PARALLEL CURRENT	(Amp)		2
RESISTANCE	(Ohm)		2.2
INDUCTANCE	(mH)		15
BIPOLAR HOLDING TORQUE	(Ncm)		360
ROTOR INERTIA	(Kgm ² x 10 ⁻⁷)		1480
THEORETICAL ACCELERATION	(rad x sec. ⁻²)		24300
BACK E.M.F.	(V/Krpm)		180
MASS	(Kg)		1.7
INTERNATIONAL STANDARDS			UL, CSA, CE, RoHS
INSULATION VOLTAGE	(V)		250 Vac (350 Vdc)
PROTECTION DEGREE - INSULATION CLASS			IP43 - F
LEADS CODE			V

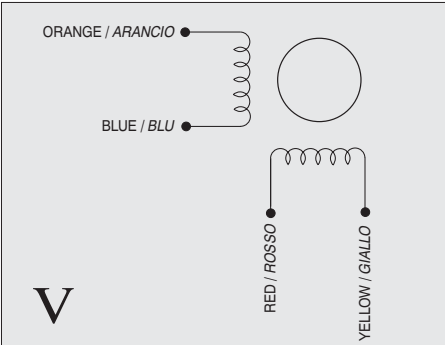
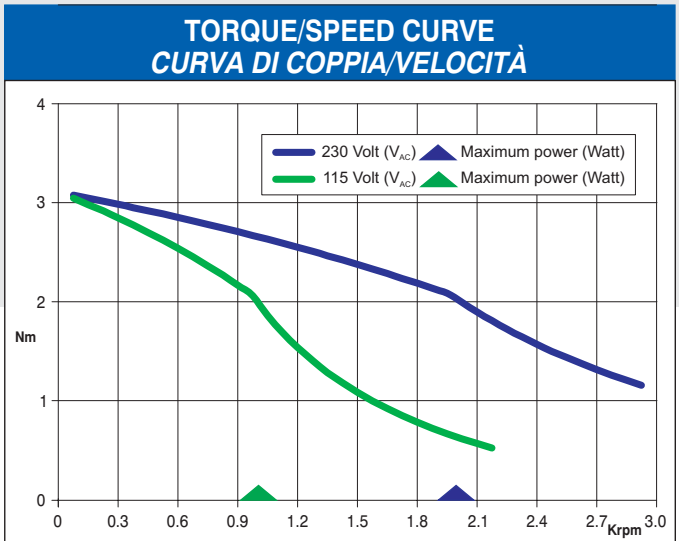

Suggested R.T.A. driver: X-PLUS B Series, X-MIND Series.

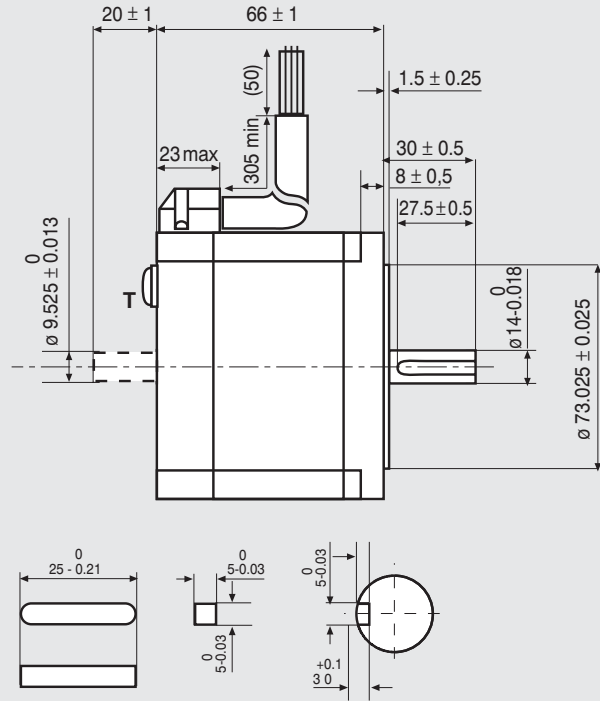
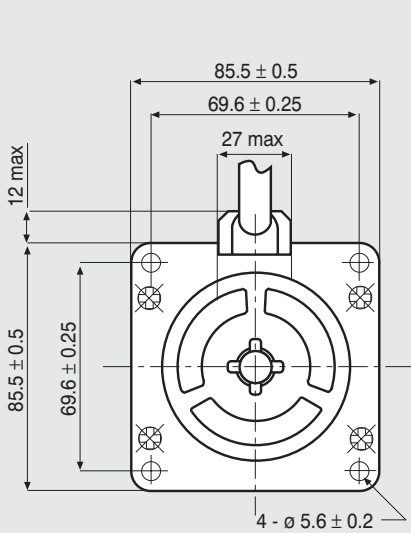

T IS THE EARTH TERMINAL.

Dimensions in mm.

FEATURES CARATTERISTICHE		MODEL MODELLO	SM2861 - 5255 (SM2861 - 5225)
BASIC STEP ANGLE			1.8° ± 0.09°
BIPOLAR PARALLEL CURRENT	(Amp)		6
RESISTANCE	(Ohm)		0.29
INDUCTANCE	(mH)		1.7
BIPOLAR HOLDING TORQUE	(Ncm)		360
ROTOR INERTIA	(Kgm ² x 10 ⁻⁷)		1480
THEORETICAL ACCELERATION	(rad x sec. ⁻²)		24300
BACK E.M.F.	(V/Krpm)		60
MASS	(Kg)		1.7
INTERNATIONAL STANDARDS			UL, CSA, CE, RoHS
INSULATION VOLTAGE	(V)		250 Vac (350 Vdc)
PROTECTION DEGREE - INSULATION CLASS			IP43 - F
LEADS CODE			V

Codes between brackets refer to double shaft models.
Le sigle fra parentesi si riferiscono ai modelli bialbero.

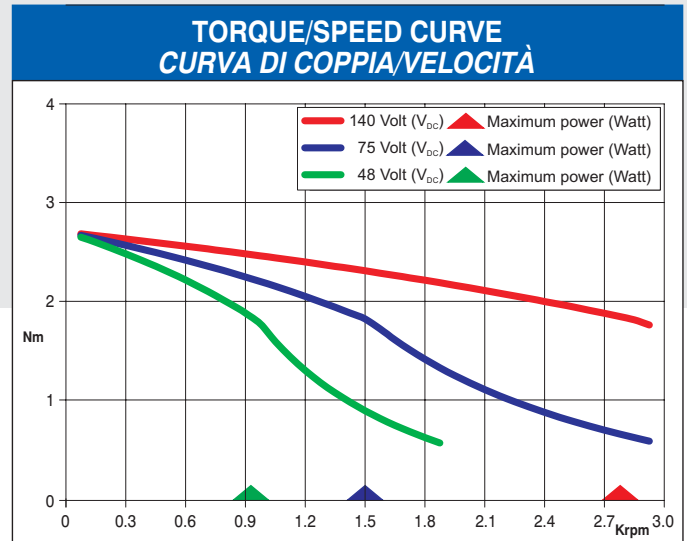

R.T.A. s.r.l. PAVIA (ITALY) SANYO DENKI CO., Ltd (JAPAN)

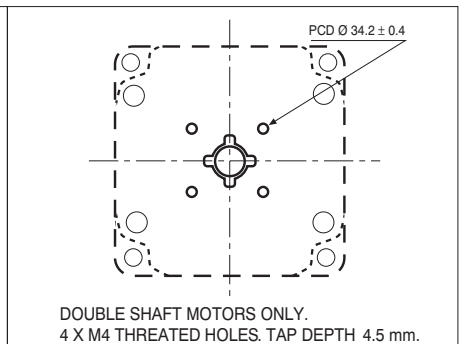
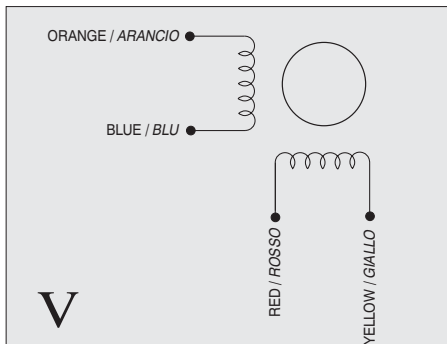

Suggested R.T.A. driver: NDC Series, HGD Series, PLUS Series.

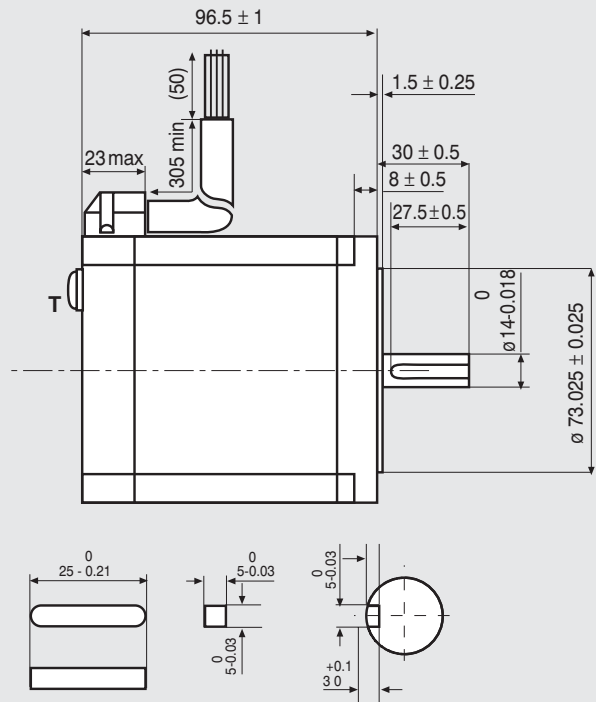
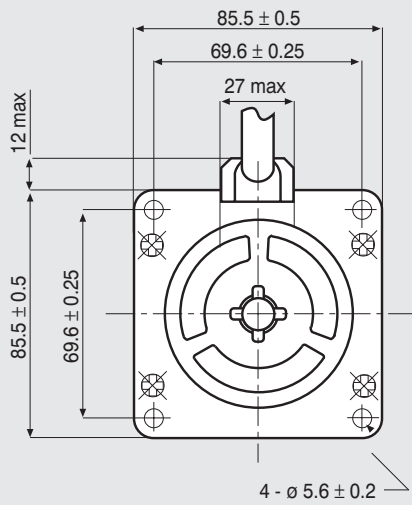

T IS THE EARTH TERMINAL.

Dimensions in mm.

FEATURES CARATTERISTICHE		MODEL MODELLO	SM2862 - 5055
BASIC STEP ANGLE			1.8° ± 0.09°
BIPOLAR PARALLEL CURRENT	(Amp)		2
RESISTANCE	(Ohm)		3.2
INDUCTANCE	(mH)		25
BIPOLAR HOLDING TORQUE	(Ncm)		700
ROTOR INERTIA	(Kg ^m 2 x 10 ⁻⁷)		3000
THEORETICAL ACCELERATION	(rad x sec. ⁻²)		23300
BACK E.M.F.	(V/Krpm)		350
MASS	(Kg)		2.9
INTERNATIONAL STANDARDS			UL, CSA, CE, RoHS
INSULATION VOLTAGE	(V)		250 V _{ac} (350 V _{dc})
PROTECTION DEGREE - INSULATION CLASS			IP43 - F
LEADS CODE			V

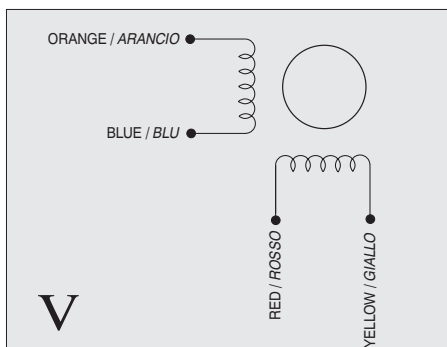
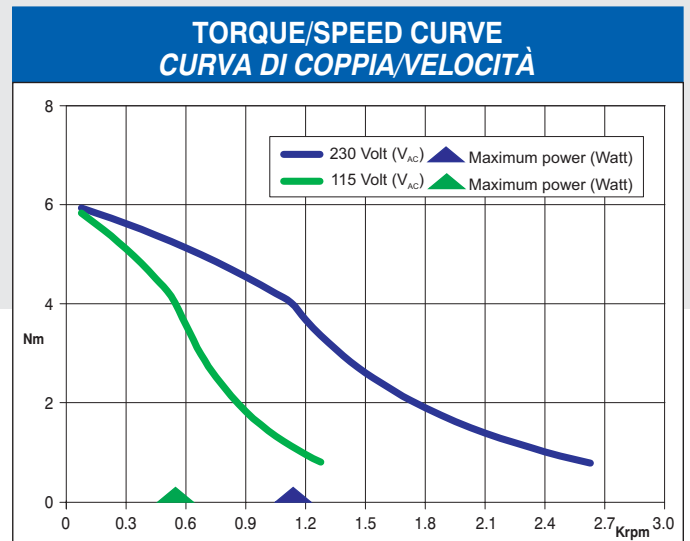

Suggested R.T.A. driver: X-PLUS B Series, X-MIND Series.

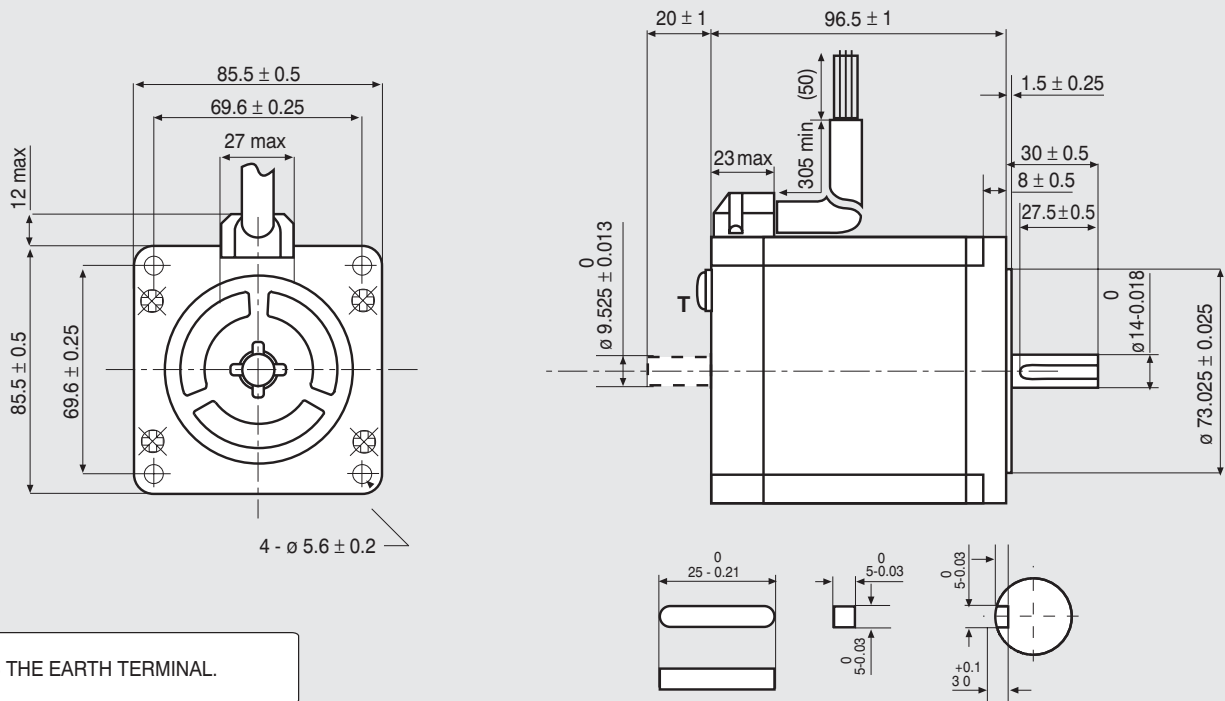

T IS THE EARTH TERMINAL.

Dimensions in mm.

FEATURES CARATTERISTICHE		MODEL MODELLO	SM2862 - 5155 (SM2862 - 5125)
BASIC STEP ANGLE			1.8° ± 0.09°
BIPOLAR PARALLEL CURRENT	(Amp)		4
RESISTANCE	(Ohm)		0.83
INDUCTANCE	(mH)		6.4
BIPOLAR HOLDING TORQUE	(Ncm)		700
ROTOR INERTIA	(Kgm ² x 10 ⁻⁷)		3000
THEORETICAL ACCELERATION	(rad x sec. ⁻²)		23300
BACK E.M.F.	(V/Krpm)		175
MASS	(Kg)		2.9
INTERNATIONAL STANDARDS			UL, CSA, CE, RoHS
INSULATION VOLTAGE	(V)		250 V _{ac} (350 V _{dc})
PROTECTION DEGREE - INSULATION CLASS			IP43 - F
LEADS CODE			V

Codes between brackets refer to double shaft models.
Le sigle fra parentesi si riferiscono ai modelli bialbero.

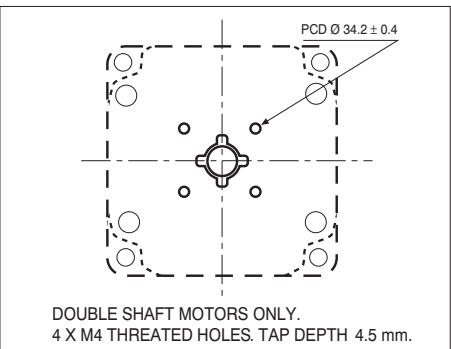
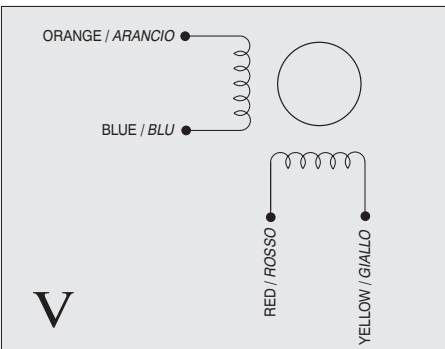
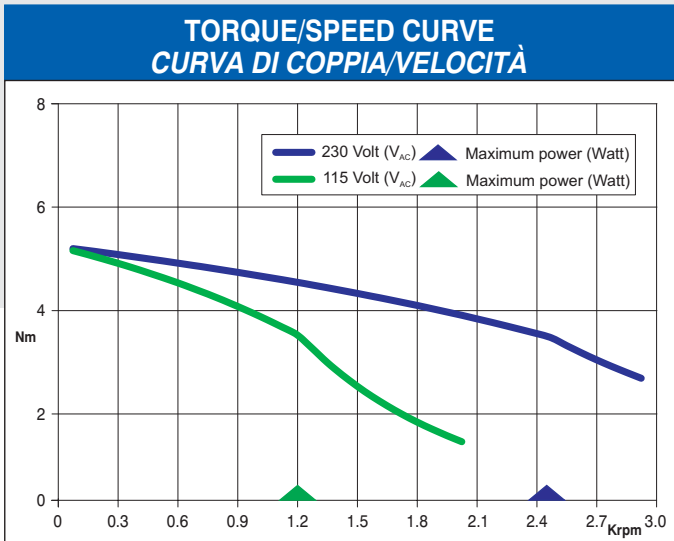

R.T.A. s.r.l. PAVIA (ITALY) SANYO DENKI CO., Ltd (JAPAN)

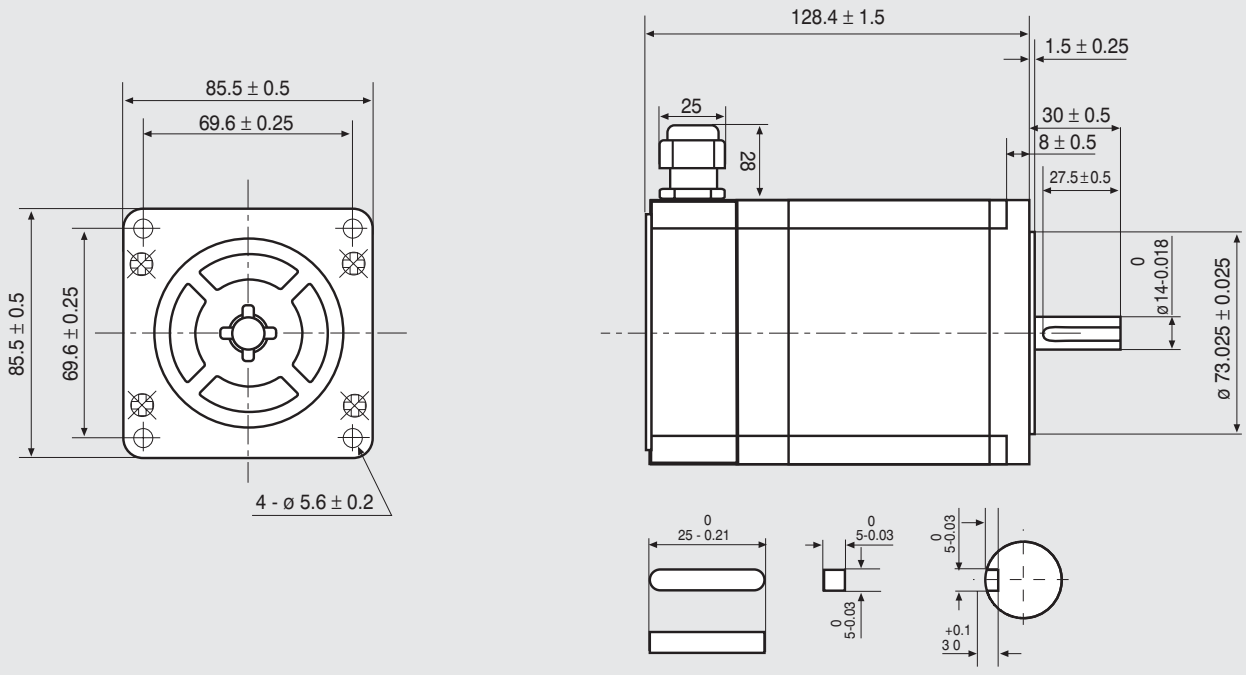

Dimensions in mm.

FEATURES CARATTERISTICHE		MODEL MODELLO	SM2862 - 5156
BASIC STEP ANGLE			1.8° ± 0.09°
BIPOLAR PARALLEL CURRENT	(Amp)		4
RESISTANCE	(Ohm)		0.83
INDUCTANCE	(mH)		6.4
BIPOLAR HOLDING TORQUE			700 (Ncm)
ROTOR INERTIA	(Kgm ² x 10 ⁻⁷)		3000
THEORETICAL ACCELERATION			23300 (rad x sec. ⁻²)
BACK E.M.F.	(V/Krpm)		175
MASS	(Kg)		2.9
INTERNATIONAL STANDARDS			UL, CSA, CE, RoHS
INSULATION VOLTAGE	(V)		250 V _{ac} (350 V _{dc})
PROTECTION DEGREE - INSULATION CLASS			IP43 - F
LEADS CODE			V

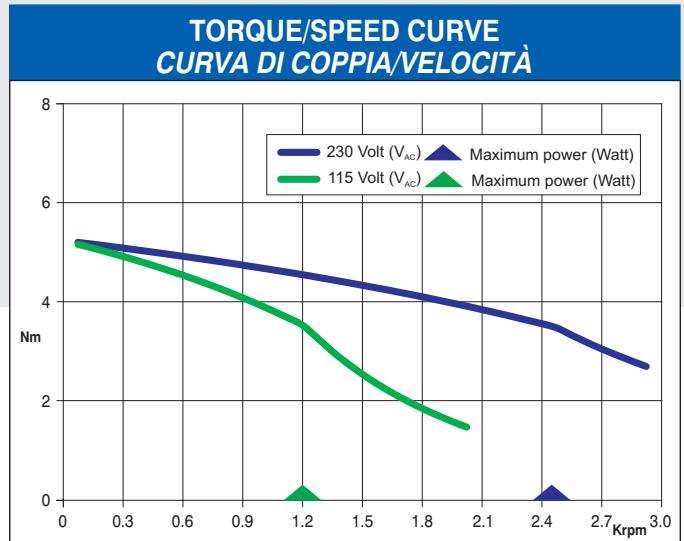

R.T.A. s.r.l. PAVIA (ITALY) SANYO DENKI CO., Ltd (JAPAN)

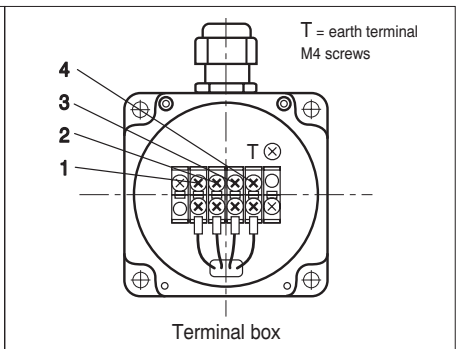
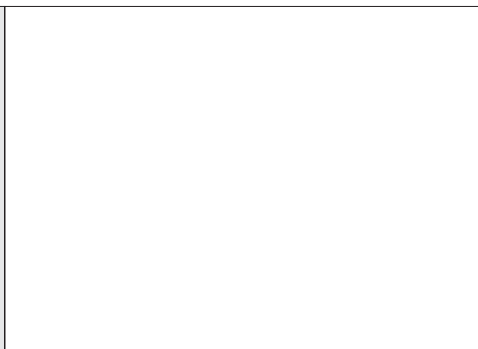
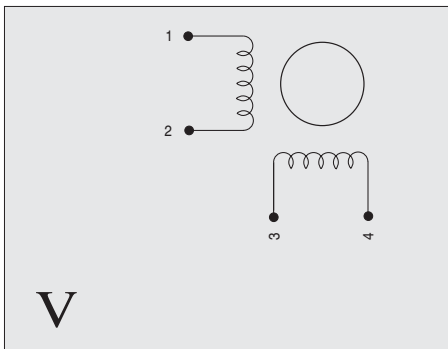

Suggested R.T.A. driver: X-PLUS B Series, X-MIND Series.

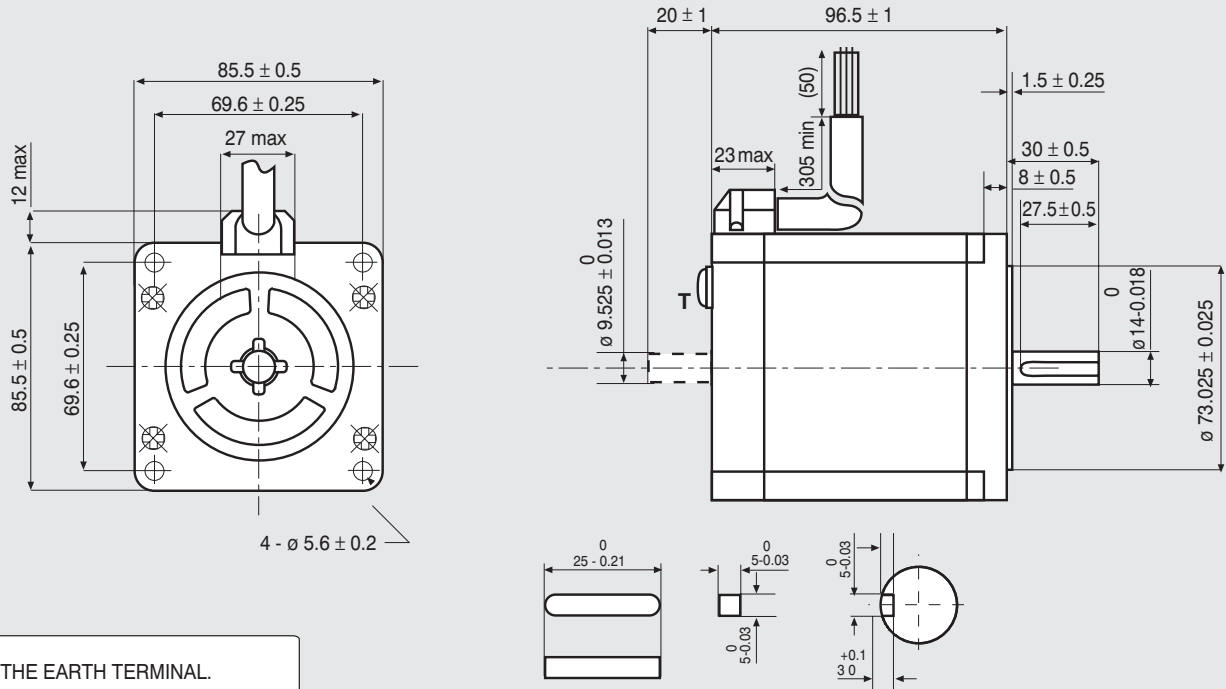

T IS THE EARTH TERMINAL.

Dimensions in mm.

FEATURES CARATTERISTICHE		MODEL MODELLO	SM2862 - 5255 (SM2862 - 5225)
BASIC STEP ANGLE			1.8° ± 0.09°
BIPOLAR PARALLEL CURRENT	(Amp)		6
RESISTANCE	(Ohm)		0.36
INDUCTANCE	(mH)		2.8
BIPOLAR HOLDING TORQUE	(Ncm)		700
ROTOR INERTIA	(Kgm ² x 10 ⁻⁷)		3000
THEORETICAL ACCELERATION	(rad x sec. ⁻²)		23300
BACK E.M.F.	(V/Krpm)		120
MASS	(Kg)		2.9
INTERNATIONAL STANDARDS			UL, CSA, CE, RoHS
INSULATION VOLTAGE	(V)		250 Vac (350 Vdc)
PROTECTION DEGREE - INSULATION CLASS			IP43 - F
LEADS CODE			V

Codes between brackets refer to double shaft models.
Le sigle fra parentesi si riferiscono ai modelli bialbero.

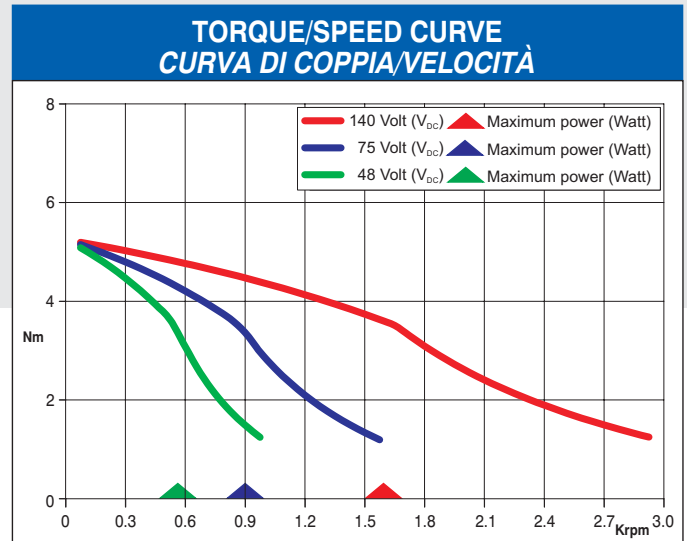

R.T.A. s.r.l. PAVIA (ITALY) SANYO DENKI CO., Ltd (JAPAN)

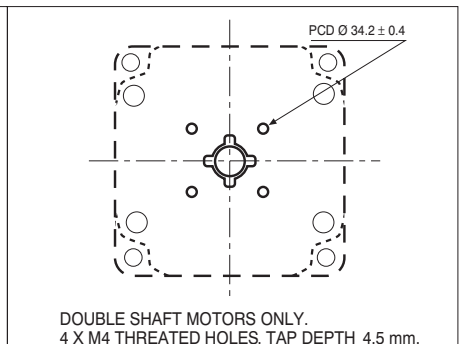
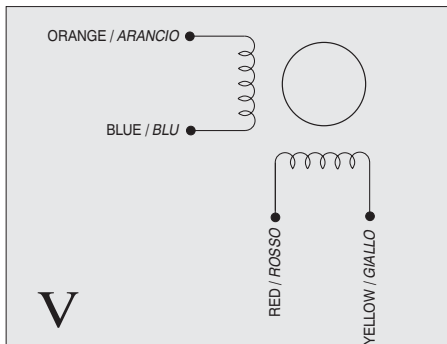

DOUBLE SHAFT MOTORS ONLY.
4 X M4 THREADED HOLES. TAP DEPTH 4.5 mm.

Suggested R.T.A. driver: NDC Series, HGD Series, PLUS Series.

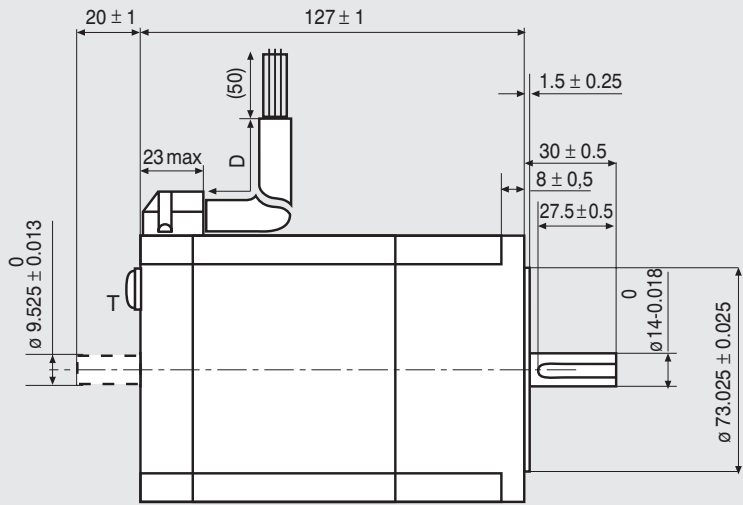
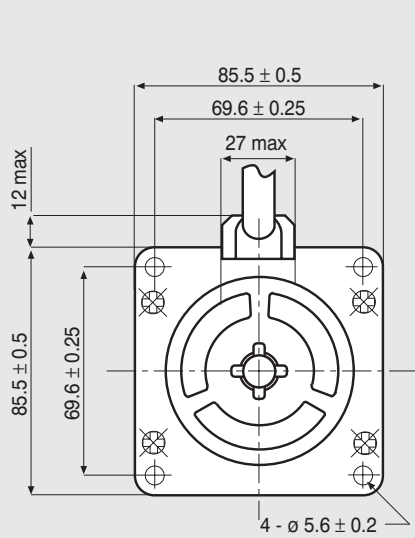

MODEL	D
SM2863-5155	305
SM2863-5126	800

T IS THE EARTH TERMINAL.

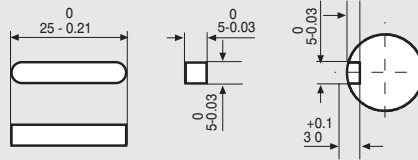

Dimensions in mm.

FEATURES CARATTERISTICHE		SM2863 - 5155 (SM2863 - 5126)
MODEL MODELLO		SM2863 - 5155 (SM2863 - 5126)
BASIC STEP ANGLE		1.8° ± 0.09°
BIPOLAR PARALLEL CURRENT	(Amp)	4
RESISTANCE	(Ohm)	1
INDUCTANCE	(mH)	7.9
BIPOLAR HOLDING TORQUE	(Ncm)	920
ROTOR INERTIA	(Kgm ² x 10 ⁻⁷)	4500
THEORETICAL ACCELERATION	(rad x sec. ⁻²)	20500
BACK E.M.F.	(V/Krpm)	241
MASS	(Kg)	4
INTERNATIONAL STANDARDS		UL, CSA, CE, RoHS
INSULATION VOLTAGE	(V)	250 Vac (350 Vdc)
PROTECTION DEGREE - INSULATION CLASS		IP43 - F
LEADS CODE		V

Codes between brackets refer to double shaft models.
Le sigle fra parentesi si riferiscono ai modelli bialbero.

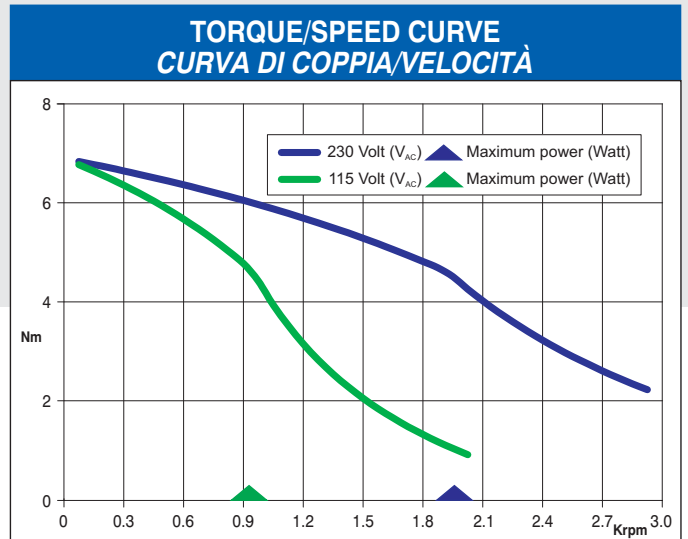

R.T.A. s.r.l. PAVIA (ITALY) SANYO DENKI CO., Ltd (JAPAN)

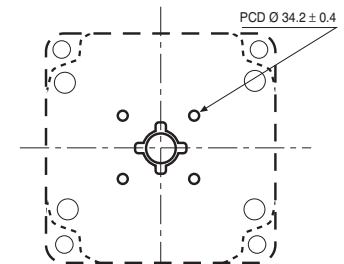
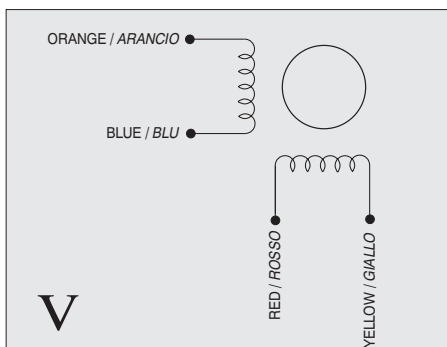

DOUBLE SHAFT MOTORS ONLY.
4 X M4 THREADED HOLES. TAP DEPTH 4.5 mm.

Suggested R.T.A. driver: X-PLUS B Series, X-MIND Series.

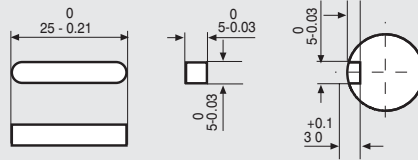
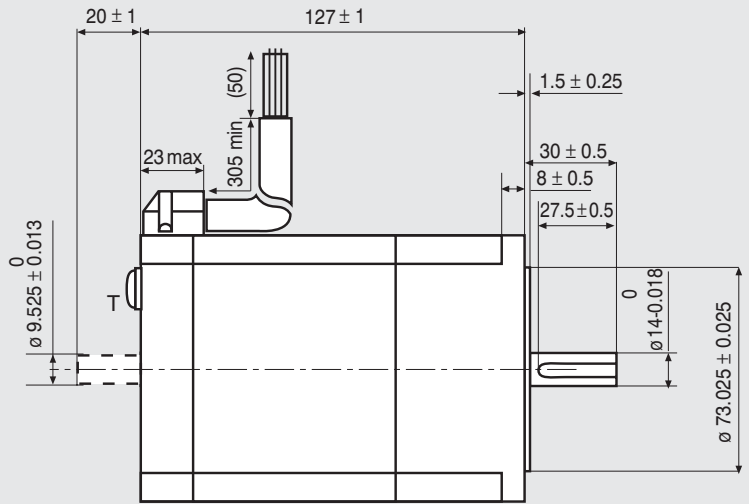
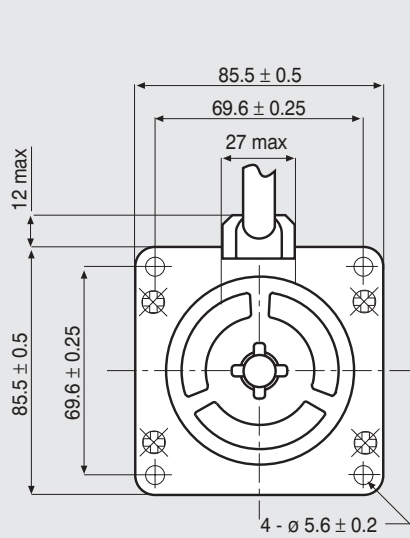

T IS THE EARTH TERMINAL.

Dimensions in mm.

FEATURES CARATTERISTICHE		MODEL MODELLO	SM2863 - 5255 (SM2863 - 5225)
BASIC STEP ANGLE			1.8° ± 0.09°
BIPOLAR PARALLEL CURRENT	(Amp)		6
RESISTANCE	(Ohm)		0.46
INDUCTANCE	(mH)		3.8
BIPOLAR HOLDING TORQUE	(Ncm)		920
ROTOR INERTIA	(Kgm ² x 10 ⁻⁷)		4500
THEORETICAL ACCELERATION	(rad x sec. ⁻²)		20500
BACK E.M.F.	(V/Krpm)		161
MASS	(Kg)		4
INTERNATIONAL STANDARDS			UL, CSA, CE, RoHS
INSULATION VOLTAGE	(V)		250 Vac (350 Vdc)
PROTECTION DEGREE - INSULATION CLASS			IP43 - F
LEADS CODE			V

Codes between brackets refer to double shaft models.
Le sigle fra parentesi si riferiscono ai modelli bialbero.

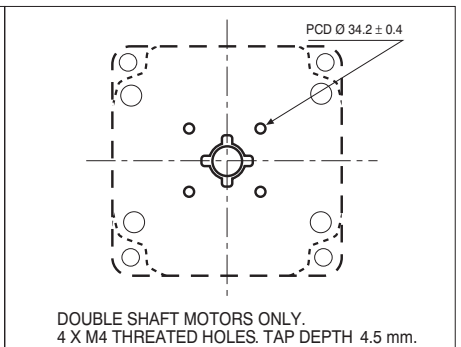
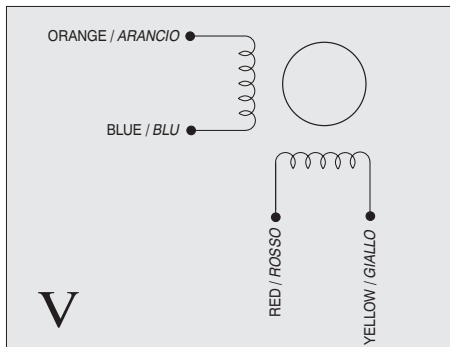
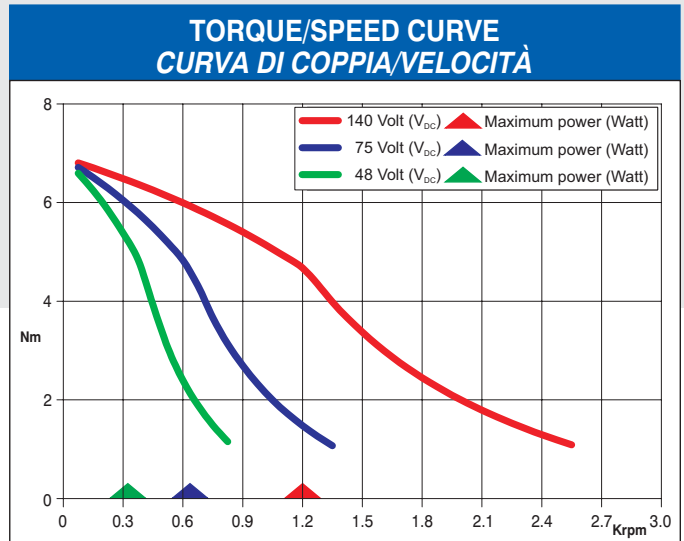

R.T.A. s.r.l. PAVIA (ITALY) SANYO DENKI CO., Ltd (JAPAN)

Suggested R.T.A. driver: NDC Series, HGD Series, PLUS Series.

LEADS CODE CODICE TERMINALI	PARALLEL BIPOLAR CONNECTION COLLEGAMENTO BIPOLARE PARALLELO	SERIES BIPOLAR CONNECTION COLLEGAMENTO BIPOLARE SERIE	UNIPOLAR CONNECTION COLLEGAMENTO UNIPOLARE
I			
II			
III			
IV			
V			
VI			

CONVERSION FACTORS

LENGTH

$$1 \text{ mm} = 3.937 \times 10^{-2} \text{ inch}$$

MASS

$$1 \text{ Kg} = 2.205 \text{ x lb force}$$

INERTIA

$$10^7 \text{ g cm}^2 = 1 \text{ Kg m}^2 = 5.467 \times 10^4 \text{ oz in}^2 = 3.417 \times 10^3 \text{ lb in}^2$$

TORQUE

$$1 \text{ Nm} = 1.416 \times 10^2 \text{ oz in} = 0.738 \text{ ft lb} = 8.85 \text{ in lb}$$
$$1 \text{ Ncm} = 1.416 \text{ oz in} = 7.38 \times 10^{-3} \text{ ft lb} = 8.85 \times 10^{-2} \text{ in lb}$$

POWER

$$1 \text{ KW} = 1.34 \text{ hp}$$
$$1 \text{ W} = 1.34 \times 10^{-3} \text{ hp}$$



HEADQUARTERS

R.T.A. s.r.l. - Via E. Mattei
Fraz. Divisa - 27020 MARCIGNAGO (PV)
Tel. +39.0382.929.855 - Fax +39.0382.929.150
www.rta.it - e-mail: info@rta.it

NORTH-EAST BRANCH

Via D. Alighieri, 4/A - 30034 MIRA (VE)
Tel. +39.041.56.00.332 - Fax +39.041.56.00.165
e-mail: rtane@rta.it

CENTER-SOUTH BRANCH

Via D. Alighieri, 41 - 60025 LORETO (AN)
Tel. +39.071.75.00.433 - Fax +39.071.97.77.64
e-mail: rtacs@rta.it

R.T.A. Deutschland GmbH

Bublitzer Straße, 34
40599 DÜSSELDORF (Germany)
Tel. +49.211.749.668.60
Fax +49.211.749.668.66
www.rta-deutschland.de
e-mail: info@rta-deutschland.de

R.T.A. IBERICA - Motion Control Systems S.L.

C/ Generalitat 22, 1° 3°
08850 GAVA - BARCELONA (Spain)
Tel. +34. 936. 388. 805
Fax +34. 936. 334. 595
www.rta-iberica.es
e-mail: info@rta-iberica.es



Motion Control Systems