

To prevent accidents arising from the misuse of this instrument, please ensure the operator receives this manual.

Safety Precautions (Be sure to read these precautions before using our products.)

The safety precautions are classified into categories: "Warning" and "Caution".

Depending on circumstances, procedures indicated by  Caution may be linked to serious results, so be sure to follow the directions for usage.



Warning

Procedures which may lead to dangerous conditions and cause death or serious injury, if not carried out properly.



Caution

Procedures which may lead to dangerous conditions and cause superficial to medium injury or physical damage or may degrade or damage the product, if not carried out properly.



Warning

- To prevent an electric shock or fire, only Shinko or qualified service personnel may handle the inner assembly.
- To prevent an electric shock, fire or damage to instrument, parts replacement may only be undertaken by Shinko or other qualified service personnel.



Safety precautions

- To ensure safe and correct use, thoroughly read and understand this manual before using this instrument.
- This instrument is intended to be used for industrial machinery, machine tools and measuring equipment. Verify correct usage after consulting purpose of use with our agency or main office. (Never use this instrument for medical purposes with which human lives are involved.)
- External protection devices such as overcurrent protection fuse, etc. must be installed, as malfunction of this product could result in serious damage to the system. Also proper periodic maintenance is required.
- This instrument must be used under the conditions and environment described in this manual. Shinko Technos Co., Ltd. does not accept liability for any injury, loss of life or damage occurring due to the instrument being used under conditions not otherwise stated in this manual.

Caution with respect to Export Trade Control Ordinance

To avoid this instrument from being used as a component in, or as being utilized in the manufacture of weapons of mass destruction (i.e. military applications, military equipment, etc.), please investigate the end users and the final use of this instrument.

In the case of resale, ensure that this instrument is not illegally exported.

● Installation precautions



Caution

This instrument is intended to be used under the following environmental conditions (IEC61010-1): Overvoltage category II, Pollution degree 2

Ensure the mounting location corresponds to the following conditions:

- A minimum of dust, and an absence of corrosive gases
- No flammable, explosive gases
- No mechanical vibrations or shocks
- No exposure to direct sunlight, an ambient temperature of 0 to 55°C (32 to 131°F) that does not change rapidly, and without icing
- An ambient non-condensing humidity of 35 to 85%RH
- No large capacity electromagnetic switches or cables through which large current is flowing.
- No water, oil or chemicals or where the vapors of these substances can come into direct contact with the unit

● Wiring precautions



Caution

- This instrument has no built-in power switch, circuit breaker or fuse. It is necessary to install them near the instrument.
(Recommended fuse: Time-lag fuse, rated voltage 250V AC, rated current 2A)

● Running and maintenance precautions



Caution

- Do not touch live terminals. This may cause electric shock or problems in operation.
- Turn the power supply to the instrument OFF before retightening the terminal and cleaning. Working or touching the terminal with the power switched ON may result in severe injury or death due to Electric Shock.
- Use a soft, dry cloth when cleaning the instrument.
(Alcohol based substances may tarnish or deface the unit.)
- Do not strike or scratch it with a hard object or press hard on it

1. Name of sections

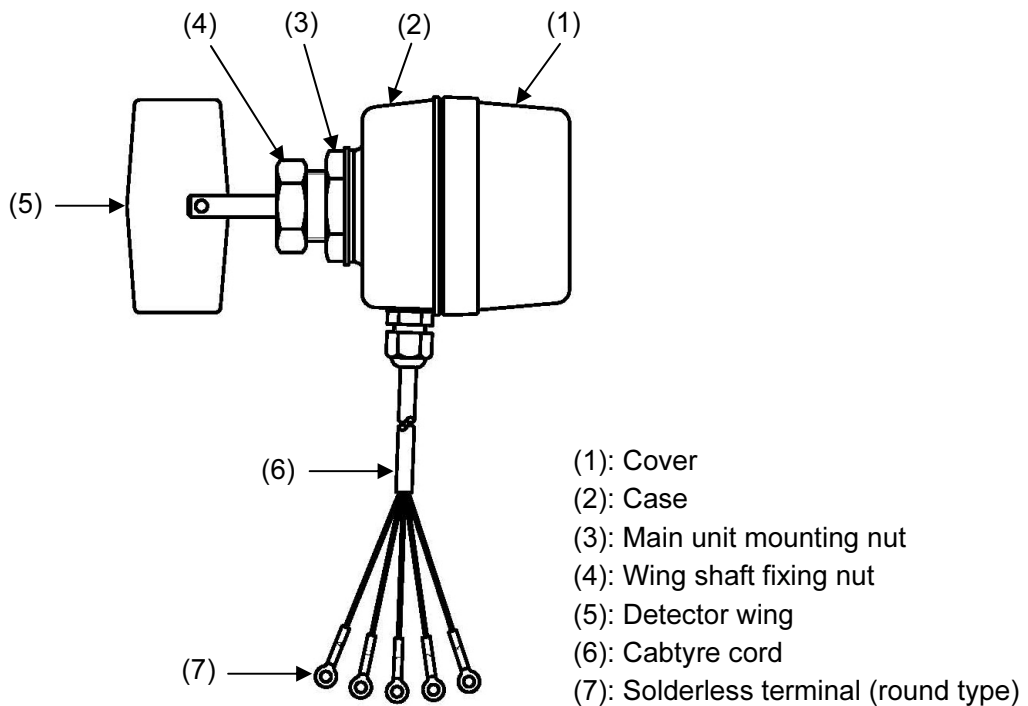

(Fig. 1.1)

2. Mounting to hopper

2.1 Site selection and precautions

Ensure the mounting location corresponds to the following conditions, and follow precautions below.

- (1) A minimum of dust, and an absence of corrosive gases
- (2) Few mechanical vibrations or shocks
- (3) No exposure to direct sunlight, an ambient temperature of 0 to 55°C (32 to 131°F) that does not change rapidly, and without icing
- (4) Mount the instrument at the position where granule level actually changes.
- (5) If the granule load is large, mount an adequate guard plate.
- (6) Avoid mounting the instrument under the falling point of granules as well as near the outlet.
- (7) Mount the unit using the Main unit mounting nut.
When it is difficult to set or remove the wing in a hopper, use a flange (sold separately).
- (8) Do not push and insert wing shaft too hard.
Insert it up to the point with ease and then revolve it manually.

2.2 Mounting examples

[Good example]

• Horizontal mounting

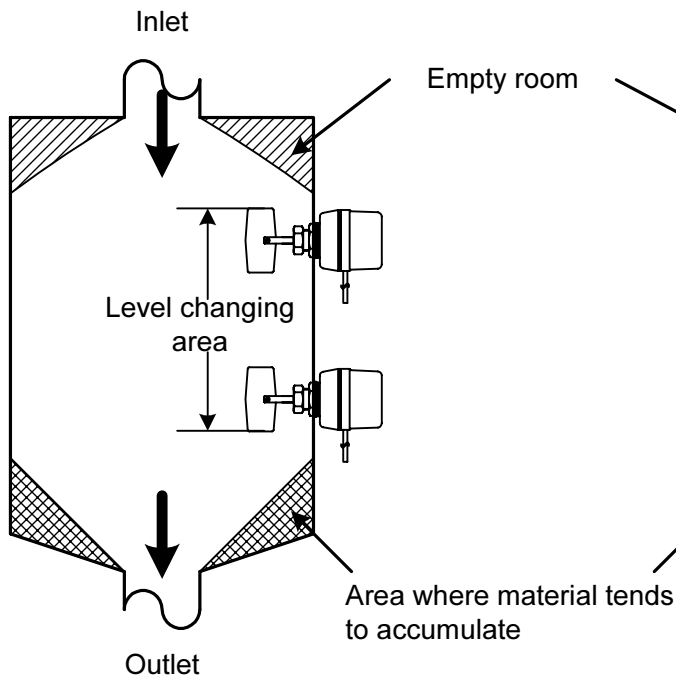

(Fig.2.2-1)

• Vertical mounting

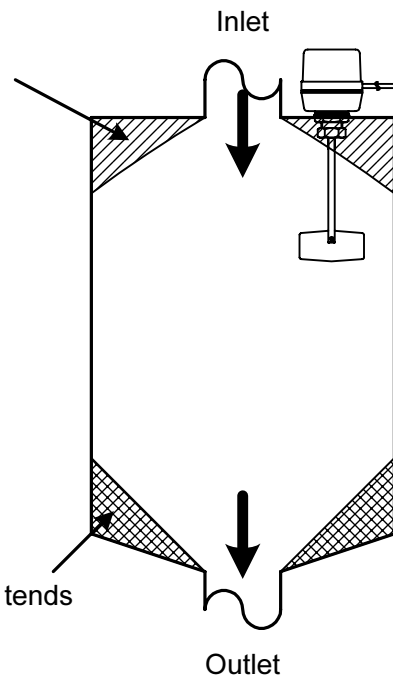

(Fig.2.2-2)

• For large loading

(Mount the guard plate when the granule loading is large.)

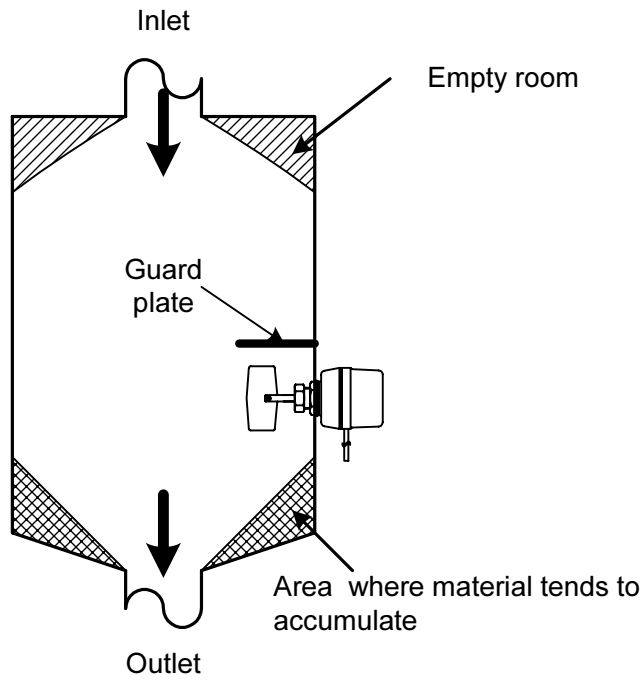

(Fig.2.2-3)

[Bad example]

• Under the inlet

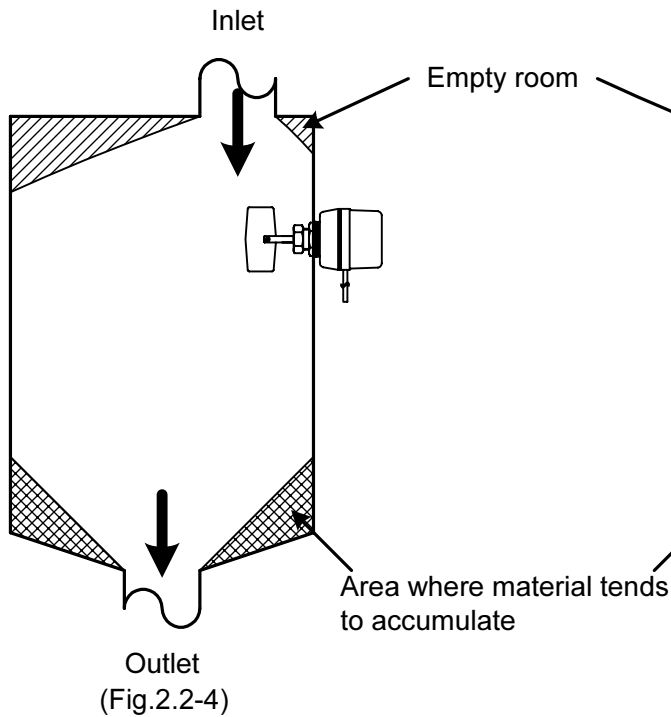

(Fig.2.2-4)

• Near the outlet

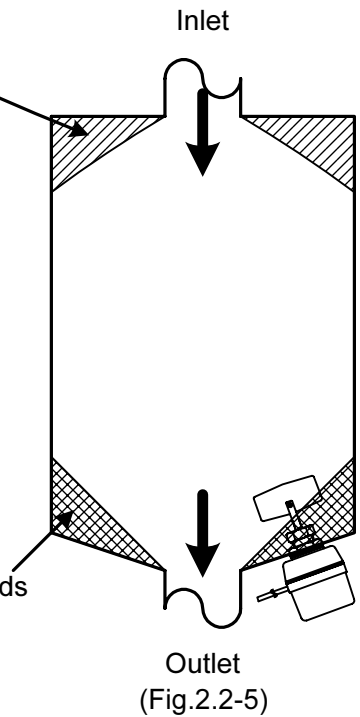

(Fig.2.2-5)

● **Nut and flange mounting**

[Nut Mounting]

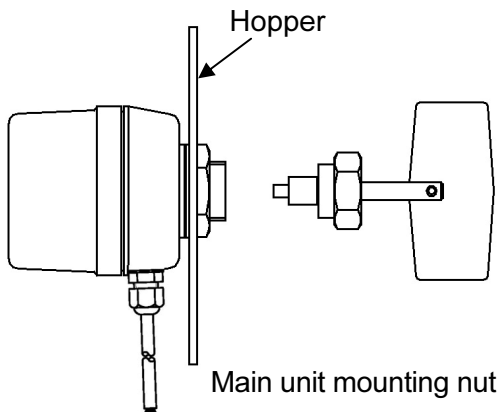

(Fig.2.2-6)

[Flange Mounting]

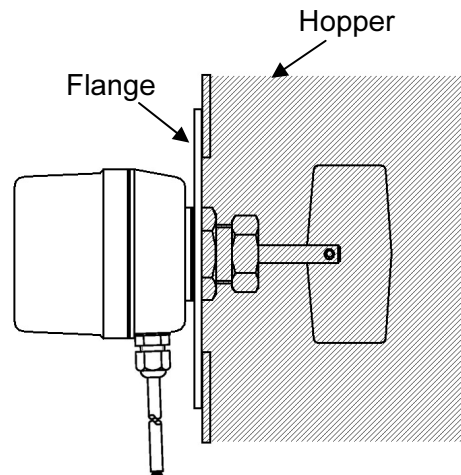

(Fig.2.2-7)

When using the LV-300 with a flange, make a hole on the hopper which enables the wing to enter.

2.3 Mounting of wing shaft

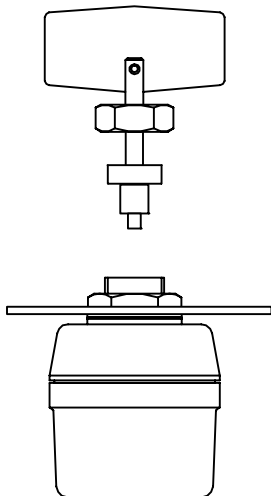

(Fig.2.3-1)

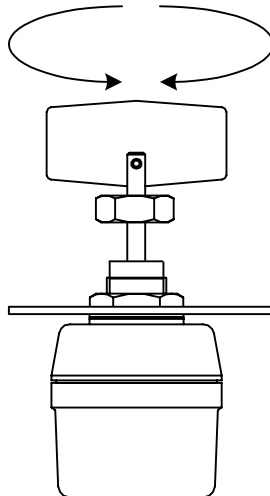

(Fig.2.3-2)

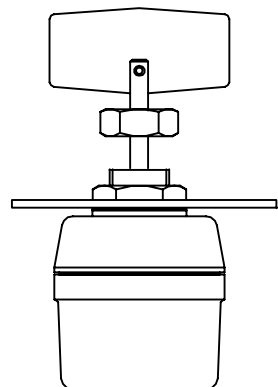

(Fig.2.3-3)

Insert the wing shaft up to the point where it can be inserted fully to the end position. When it is difficult to insert the wing shaft to the end, revolve the wing shaft manually clockwise or counterclockwise. (See Fig.2.3-2)

Tighten the wing shaft with the fixing nut. (See Fig.2.3-3)

Notice

Tighten the wing shaft fixing nut and main unit mounting nut with the specified torque as shown below, otherwise the screws will be damaged.

(Table 2.3-1)

	Appropriate torque	Maximum torque
Wing shaft fixing nut	15 N•m	Within 30 N•m
Main unit mounting nut	20 N•m	Within 30 N•m

2.4 External dimensions (Scale: mm)

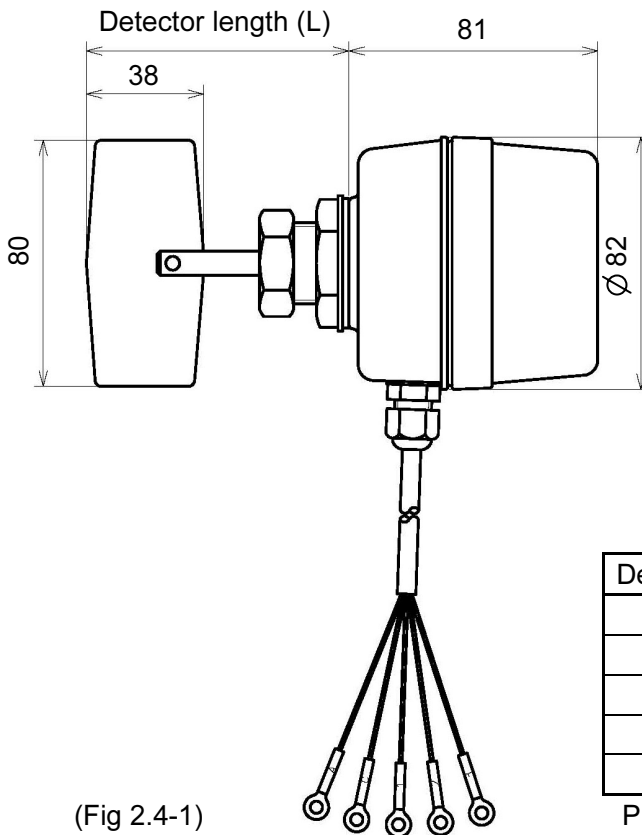

Detector wing (L)	Mounting direction
85mm	—
100mm	—
150mm	—
200mm	Vertical mounting
250mm	Vertical mounting

Please specify the detector length when ordering.

2.5 Hopper cutout (Scale: mm)

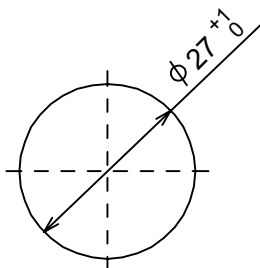

3. Terminal arrangement



Warning

Turn the power supply to the instrument OFF before wiring and checking.
Working or touching the terminal with the power switched ON may result in severe injury or death due to Electric Shock.



Caution

This instrument has no built-in power switch or fuse.
It is recommended that power switch and fuse be set at the external circuit near this instrument.

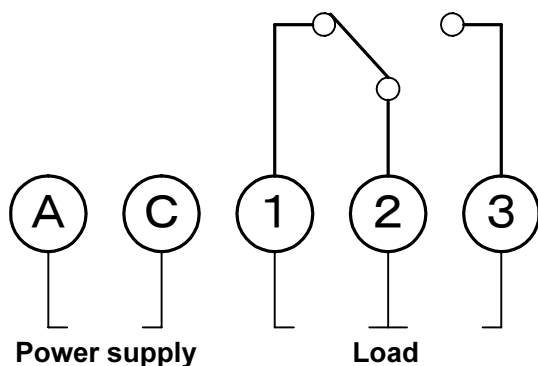

Terminal code	Lead wire color
A	White
C	Orange
1	Black
2	Brown
3	Green

● Solderless terminal for the cable cord

Use a solderless terminal in which an M4 screw fits as shown in (Fig 3-1).

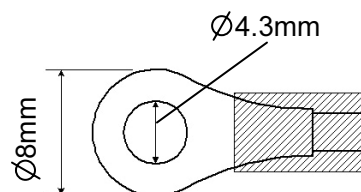

(Fig. 3-1)

4. Operation and action

4.1 Operation

When mounting to the hopper and wiring are completed, check the action as follows.

- (1) Turn the power supply to this instrument ON.
- (2) Detector wing starts to revolve with no load.
(Between terminal ① and ② is conducted. Between terminal ② and ③ is open.)
- (3) When the load is added to the detector wing, the wing stops rotating.
(Between terminal ① and ② is open. Between terminal ② and ③ is conducted.)

4.2 Action

When granule resistance is applied to the detector wing, the wing stops because the granule resistance keeps it from revolving.

Micro switch between terminal ② and ③ for internal load is conducted by the bar fixed on the motor.

When the granule resistive load is given, power supply for the motor is disconnected because the micro-switch for the motor operates.

When the granule level lowers, the detector wing is exposed, granule resistance does not work and the detector wing starts to revolve with the motor.

Micro switch between terminal ① and ② for internal load is conducted at this time.

5. Specifications

Name	: Level switch
Model name	: LV-300
Torque	: Detecting torque: 0.049N•m (0.5kg•cm) or more (fixed)
Number of revolution	: 1min ⁻¹ (60Hz)
Supply voltage	: 100V, 110V, 115V, 200V, 220/230V, 240V AC (Must be specified) 50/60Hz
Allowable voltage fluctuation range	: ±15% of the Supply voltage
Contact capacity	: 3A 250V AC (resistive load)
Ambient temperature	: 0 to 55°C
Detector length	: 85, 100, 150, 200, 250mm (Must be specified)
Mounting	: Nut screwing (Mounting part thickness: Maximum 7mm)
Material	
Case, Cover	: Aluminum die-cast
Detector shaft	: Stainless steel Ø8.0mm
Detector wing	: Stainless steel t1.5mm
Lead wire	: 5-core cabtyre cord, Length: 2m
Weight (Including cabtyre cord 2m)	

Detector length	85mm	100mm	150mm	200mm	250mm
Weight	Approx. 645g	Approx. 650g	Approx. 670g	Approx. 690g	Approx. 710g

Color

Case, Cover : 7.5BG4/2.5 (munsell value)

Dust-proof/Drip-proof structure : IP66 (excluding parts from the Main unit mounting nut to detector wing)

SHINKO TECHNOS CO., LTD. OVERSEAS DIVISION

Reg. Office : 2-5-1, Senbahigashi, Minoo, Osaka, Japan

URL : <http://www.shinko-technos.co.jp>

E-mail : overseas@shinko-technos.co.jp

Tel : 81-72-727-6100

Fax: 81-72-727-7006